



SILVERSON

**INSTALLATION, OPERATING &
MAINTENANCE INSTRUCTIONS**

**MANUAL
FOR**

**HIGH SHEAR
LABORATORY MIXER**

**MODEL
L5M-A**

**With Addendum
for the
Ultramix Mixing
Assembly**



Silverson Machines Inc . 355 Chestnut Street . East Longmeadow . MA . 01028

Tel: (413) 525 4825 . Fax: (413) 525 5804

Web: www.silverson.com . Email: sales@silverson.com

IDENTIFICATION:

This Manual is supplied in conjunction with:

Mixer Serial Number: _____

INDEX

| | | |
|-------|---|----|
| | IDENTIFICATION: | 1 |
| 1.0 | INTRODUCTION | 5 |
| 2.0 | SAFETY | 6 |
| 3.0 | INSTALLATION | 7 |
| 3.1 | UNPACKING (Refer to Fig 1) | 7 |
| 3.2 | ELECTRICAL INSTALLATION | 8 |
| 3.3 | ATTACHING THE MIXING ASSEMBLIES (Refer to FIG. 2) | 8 |
| 4.0 | DESCRIPTION | 9 |
| 4.1 | GENERAL | 9 |
| 4.1.1 | THE MIXER BODY | 9 |
| 4.1.2 | THE BASE ASSEMBLY | 9 |
| 4.1.3 | THE COLUMN UNIT | 10 |
| 4.2 | ACCESSORIES | 10 |
| 4.3 | STANDARD MIXING ASSEMBLY | 10 |
| 4.3.1 | MIXING ASSEMBLY (FIG. 4) | 10 |
| 4.4 | HEADS AND SCREENS | 11 |
| 4.5 | OPTIONAL ACCESSORIES - TUBULAR MIXING ASSEMBLIES | 12 |
| 4.6 | OPTIONAL ACCESSORIES - LABORATORY IN-LINE MIXING ASSEMBLY | 13 |
| 4.7 | OPTIONAL ACCESSORIES - LABORATORY DUPLEX MIXING ASSEMBLY | 14 |
| 5.1 | OPERATION (Refer to Fig. 8) | 15 |
| 5.2 | GENERAL GUIDELINES FOR MIXING (Refer to Figs. 9a & 9b) | 17 |
| 5.3 | DISINTEGRATING LARGE SOLIDS & AGGLOMERATES INTO LIQUIDS | 17 |
| 5.4 | DISPERSING POWDERS INTO LIQUIDS | 18 |
| 5.5 | SMALL SOLID PARTICLE SIZE REDUCTION | 18 |
| 5.6 | DISINTEGRATING SOLIDS INTO LIQUIDS | 18 |
| 5.7 | BLENDING | 18 |
| 5.8 | DISPERSING GUMS & THICKENERS | 18 |
| 5.9 | EMULSIONS | 19 |
| 5.10 | TISSUE HOMOGENISATION | 19 |
| 5.11 | TUBULAR MIXING ASSEMBLY | 19 |
| 5.12 | LABORATORY DUPLEX MIXING ASSEMBLY | 19 |
| 5.13 | IN-LINE MIXING ASSEMBLY | 20 |
| 5.14 | CLEANING | 20 |
| 5.15 | CHANGING THE HEAD / SCREEN - STANDARD MIXING ASSEMBLY | 21 |
| 5.16 | FITTING THE AXIAL FLOW HEAD TO THE STANDARD MIXING ASSEMBLY | 21 |
| 5.17 | CHANGING THE HEAD / SCREEN - TUBULAR MIXING ASSEMBLY | 22 |
| 5.18 | CHANGING THE HEAD / SCREENS - LABORATORY DUPLEX MIXING ASSEMBLY | 22 |
| 6.3 | REPLACING THE BUSH OF THE 1", 3/4" and 5/8" TUBULAR MIXING ASSEMBLIES | 25 |

| | | |
|---------------|--|-----------|
| 6.4 | REPLACING THE BUSH OF THE 3/8" MINI-MICRO TUBULAR MIXING ASSEMBLY | 26 |
| 6.5 | REPLACING THE BUSH - LABORATORY DUPLEX MIXING ASSEMBLY | 27 |
| 6.6 | REPLACING THE BUSH - LABORATORY IN-LINE MIXING ASSEMBLY. | 28 |
| 6.7 | REPLACING THE MECHANICAL SHAFT SEAL - IN-LINE MIXING ASSEMBLY (SEE FIG. 21). | 29 |
| 6.8 | GAINING ACCESS TO THE MIXER BODY INTERIOR | 29 |
| | (IN ORDER TO CARRY OUT INSTRUCTION 6.9) | 29 |
| 6.9 | REPLACING THE MOTOR BRUSHES AND CLEANING THE MOTOR ARMATURE | 30 |
| 6.10 | TROUBLE SHOOTING | 31 |
| 7.0 | TECHNICAL SPECIFICATION | 32 |
| 8.0 | ILLUSTRATED PARTS LIST | 33 |
| | General Laboratory Mixer Assembly | 33 |
| | Standard Mixing Assembly | 34 |
| | 1" and 3/4" Tubular Mixing Assembly | 35 |
| | 5/8" and 3/8" Micro Tubular Mixing Assembly | 36 |
| | Laboratory Duplex Mixing Assembly | 37 |
| | Laboratory In-Line Mixer Assembly | 38 |
| | Addendum for Ultramix Mixing Assembly | 39 |
| 1A.0 | INTRODUCTION - REFER TO MAIN MANUAL | 40 |
| 2A.0 | SAFETY | 40 |
| 3A.0 | INSTALLATION | 40 |
| 3A.2 | ELECTRICAL INSTALLATION - REFER TO MAIN MANUAL | 40 |
| 3A.3 | FITTING THE ULTRAMIX MIXING ASSEMBLY (Refer to FIG. 1A) | 40 |
| 4A.0 | DESCRIPTION | 41 |
| 4.1 | GENERAL - REFER TO MAIN MANUAL | 41 |
| 4.1.1 - 4.1.3 | - REFER TO MAIN MANUAL | 41 |
| 5A.1 | OPERATION - REFER TO MAIN MANUAL (except for caution below) | 42 |
| 5A.2 | GENERAL GUIDELINES FOR MIXING REFER TO MAIN MANUAL (except for caution below) | 42 |
| 5A.3 | PRINCIPLES OF ULTRAMIX OPERATION | 42 |
| 5A.4 | CLEANING | 43 |
| 6A.0 | MAINTENANCE PROCEDURES | 44 |
| 6A.2 | REPLACING THE PTFE OR RULON BUSH | 45 |
| 6A.3 | GAINING ACCESS TO THE MIXER BODY INTERIOR - REFER TO MAIN MANUAL (SECTION 6.8) (IN ORDER TO CARRY OUT INSTRUCTION 6A.4.). | 45 |
| 6.4A | REPLACING THE MOTOR BRUSHES AND CLEANING THE MOTOR ARMATURE - MODELS L5M AND L5T - REFER TO MAIN MANUAL (SECTION 6.9A). | 45 |
| 6.4B | REPLACING THE MOTOR BRUSHES AND CLEANING THE MOTOR ARMATURE - MODEL L5M-A - REFER TO MAIN MANUAL (SECTION 6.9B). | 45 |
| 6A.10 | TROUBLE SHOOTING - REFER TO MAIN MANUAL (SECTION 6.10) | 45 |
| 7A.0 | TECHNICAL SPECIFICATION - REFER TO MAIN MANUAL (SECTION 7.0) | 45 |
| 8A.0 | ILLUSTRATED PARTS LIST | 46 |

LIST OF ILLUSTRATIONS

| | |
|--|----|
| Fig. 1 Unpacking The Mixer | 7 |
| Fig. 2 Fitting The Standard Mixing Assembly | 8 |
| Fig. 3 The L5M-A Mixer Assembly | 9 |
| Fig. 4 Standard Mixing Assembly | 10 |
| Fig. 5 Tubular Mixing Assembly | 12 |
| Fig. 6 Laboratory In-Line Mixing Assembly | 13 |
| Fig. 7 Laboratory Duplex Mixing Assembly | 14 |
| Fig. 8 Operating The L5M-A Mixer Assembly | 15 |
| Fig. 9a Mixing Techniques | 17 |
| Fig. 9b Mixing Techniques | 17 |
| Fig. 11 Fitting the Axial Flow Head | 21 |
| Fig. 10 Changing the Head of the Head/Screen of the Standard Mixing Assembly | 21 |
| Fig. 14 Changing the Upper Head / Screen - Duplex Mixing Assembly | 22 |
| Fig. 13 Changing the Lower Head / Screen - Duplex Mixing Assembly | 22 |
| Fig. 12 Changing the Head / Screen - Tubular Mixing Assembly | 22 |
| Fig. 15 Changing the Lower Head / Screen - in-Line Mixing Assembly | 23 |
| Fig. 16 Replacing the Bush of the Standard Mixing Assembly | 25 |
| Fig. 17 Replacing the Bush of the 3/4" & 5/8" Mixing Assembly | 25 |
| Fig. 18 Replacing the Bush of the 3/8" Mlni Micro Mixing Assembly | 26 |
| Fig. 19 Replacing the Bush of the Laboratory Duplex Mixing Assembly | 27 |
| Fig. 20 Replacing the Bush - Laboratory In-Line Mixing Assembly | 28 |
| Fig. 21 Replacing the Mechanical Shaft Seal - Laboratory In-Line Mixing Assembly | 29 |
| Fig. 22 Gaining Access to the Mixer Body | 29 |
| Fig. 23 Replacing the Motor Brushes and cleaning the Motor Armature | 30 |

Addendum Illustrations

| | |
|---|----|
| Fig. 1A Fitting The Ultramix Mixing Assembly | 40 |
| Fig. 2A The L5M-A Laboratory Mixer Fitted with a Ultramix Mixing Assembly | 41 |
| Fig. 3A Principles of Ultramix Operation | 42 |
| Fig. 24 Replacing the Workhead of the Ultramix Mixing Assembly | 44 |

1.0 INTRODUCTION

The purpose of this manual is to provide you with the information needed to install, operate and maintain your Silverson High Shear In-Line Mixer.

With over 70 years of manufacturing experience Silverson has established an unequalled reputation for quality and reliability and we want you to get the best possible performance from your mixer.

IMPORTANT: Please read this manual carefully before attempting to set up or operate your machine. Neither Silverson Machines nor their representatives can accept responsibility for damage or injury resulting from improper set up or use. If you have any questions, please contact our Technical Service Department, or our representatives who will be pleased to help you.

1.1 WARRANTY

Silverson Machines Inc offers comprehensive after-sales services. If any major fault develops, the mixer should be returned for repair and / or service

The nature of the fault should be fully described and the Model and serial number of the machine quoted in any accompanying correspondence

Repair or replacement under warrantee will be effected without charge for up to 1 year from the date of purchase.

The mixer must only be shipped suitably packed and with the approval of Silverson Machines or their accredited representatives

1.2 TECHNICAL SERVICE

Spare parts and advice regarding the operation of your machine can be obtained from the Technical Service Department:

SILVERSON MACHINES INC TEL:(413) 525 4825
355 CHESTNUT STREET FAX:(413) 525 5804
EAST LONGMEADOW
MA. 01028
U.S.A

or our appointed agents

IMPORTANT: If you require spare parts or after sales service or assistance, please specify the machine model number and serial number; these are the numbers on the name plate attached to the rear panel of the mixer base.



NOTE: When returning a unit for inspection / repair ship the mixer: ATTN: REPAIRS with a letter including your name, telephone number and description of problem.

2.0 SAFETY

2.1 Throughout this manual you will find WARNINGS and CAUTIONS associated with certain procedures.



DANGER: INDICATES AN IMMINENTLY HAZARDOUS SITUATION WHICH, IF NOT AVOIDED, WILL RESULT IN DEATH OR SERIOUS INJURY.



WARNING: INDICATES A POTENTIALLY HAZARDOUS SITUATION WHICH, IF NOT AVOIDED, COULD RESULT IN DEATH OR SERIOUS INJURY.



CAUTION: Indicates a potentially hazardous situation which, if not avoided, may result in minor or moderate injury. It may also be used to alert against unsafe practices.



NOTICE: Indicates that the machine may be damaged if care is not taken when performing the procedure.

2.2 **PRIOR TO UNPACKING THE LABORATORY MIXER:** To avoid damaging the mixing unit refer to chapter 3.1 of this Manual for step by step instructions for unpacking the unit.

2.3 Please observe the Health and Safety regulations applicable to your particular location; these vary from country to country but their substance is the same - avoid all hazards to personnel and property.



WARNING: DO NOT USE THE MACHINE IN A HAZARDOUS AREA WHERE A FLAMMABLE OR EXPLOSIVE ATMOSPHERE MAY BE PRESENT. THIS MACHINE IS NOT EXPLOSION PROOF / FLAME PROOF.



WARNING: NEVER TOUCH ROTATING PARTS. FAILURE TO OBSERVE THIS MAY RESULT IN BODILY INJURY.



CAUTION: Use special care when handling the Mixing Assemblies - THEY MAY BE SHARP!



WARNING: IF USING SOLVENTS TO CLEAN COMPONENTS, USE IN A WELL VENTILATED AREA AND AVOID INHALATION OF FUMES. KEEP AWAY FROM SOURCES OF IGNITION :- NO SMOKING.

2.4 Never use parts other than those supplied or recommended by Silverson Machines Inc. The use of such parts will nullify any warranties and may cause premature wear or more seriously may cause component failure and possible injury.

2.5 Check that the voltage, phases and cycles (Hz) on the electrical data plate located on the rear panel of the mixer body are compatible with the available electricity supply.



WARNING: BEFORE STARTING THE MIXER ALWAYS ENSURE THAT THE SHAFT COUPLING SLEEVE IS IN ITS CORRECT OPERATING POSITION AND THAT THE COUPLING PIN IS CAPTIVATED BY THE SLEEVE AS SHOWN.



WARNING: ALWAYS DISCONNECT THE MACHINE FROM THE ELECTRICITY SUPPLY BEFORE CARRYING OUT ANY MAINTENANCE WORK. SILVERSON MACHINES SHOULD BE CONSULTED BEFORE CARRYING OUT ANY MAINTENANCE WORK WHICH IS NOT DESCRIBED IN THIS MANUAL.



WARNING: ANY ELECTRICAL OPERATION SHOULD ONLY BE CARRIED OUT BY A SUITABLY QUALIFIED ELECTRICIAN.



WARNING: NEVER CARRY OUT ANY MAINTENANCE WORK OR REMOVE THE MIXING ASSEMBLY OR HEAD/ SCREEN WHILE THE MACHINE IS RUNNING OR IS STILL CONNECTED TO THE ELECTRICAL SUPPLY. FAILURE TO OBSERVE THIS MAY RESULT IN BODILY INJURY.

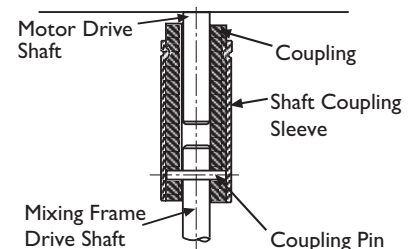

3.0 INSTALLATION

3.1 UNPACKING (Refer to Fig 1)



WARNING WHEN LIFTING THE MACHINE FROM THE PACKING CASE DO NOT LIFT BY THE TUBE (B). TAKE CARE TO AVOID ANY MOVEMENT OF THE TUBE WHILE UNPACKING THE MACHINE AS DAMAGE TO THE COUPLING MAY OCCUR.

3.1.1 Stand the machine on its base on a table or workbench of convenient height.

3.1.2 Cut tension strap (A)



Note: The weight of the motor unit is now supported by tube (B). This must not under any circumstances be removed by forcing it in any direction.

3.1.3 Peel off the yellow tape which is wrapped around both tube (B) and sleeve (D).

3.1.4 Grip tube (B) firmly with one hand and with the other hand turn the sleeve (D) in the direction of the red arrow; continue turning the sleeve until it is screwed down to its lowest position.

3.1.5 Next cut the adhesive tape which is securing the wood brace (C) at each end. Take care not to damage the machine.

3.1.6 Lift tube (B) together with sleeve (D) vertically upwards taking care not to pull sideways when carrying out this operation. You should now be able to slide out the wood brace (C).

3.1.7 Now the tube (B) and sleeve (D) may be lowered and in the lowest position the lower end of the tube be gently pulled towards the front of the machine base, the upper end of sleeve (D) should disengage easily from the motor shaft without imposing any strain whatsoever on the motor shaft or its coupling.

3.1.8 Finally there is a loose flat steel washer which will fall away freely with the removal of the tube. We suggest that this washer, together with the tube/sleeve and wood brace be stored away ready for re-use in order to transport the mixer in the future.

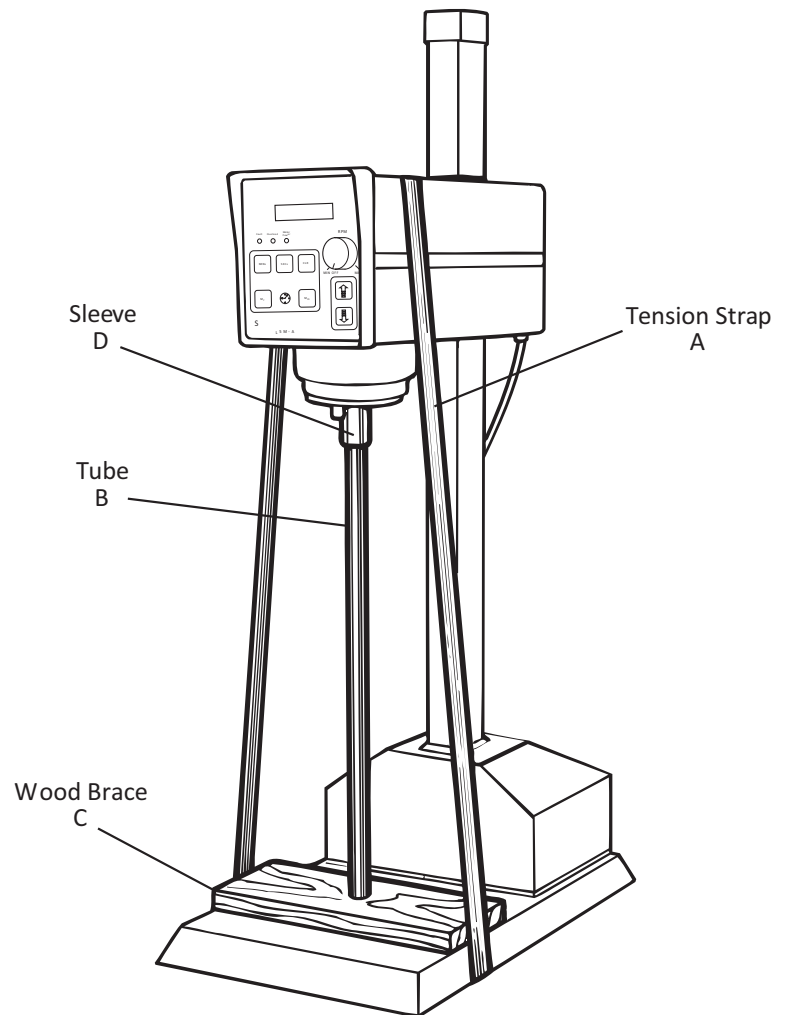

Fig. 1 Unpacking The Mixer

3.2 ELECTRICAL INSTALLATION

3.2.1 The machine must be connected to an AC power supply outlet with an earthed socket. The voltage indicated on the electrical data plate located on the rear panel of the mixer body must be compatible with the mains voltage of your electrical supply.



WARNING: ANY ELECTRICAL OPERATIONS OR MAINTENANCE SHOULD ONLY BE CARRIED OUT BY A SUITABLY QUALIFIED ELECTRICIAN.



WARNING: DO NOT USE THE MACHINE IN A HAZARDOUS AREA WHERE A FLAMMABLE OR EXPLOSIVE ATMOSPHERE MAY BE PRESENT. THIS MACHINE IS NOT EXPLOSION PROOF / FLAME PROOF.

3.3 ATTACHING THE MIXING ASSEMBLIES (Refer to FIG. 2)

3.3.1 Unscrew and remove the two knurled nuts (H).

3.3.2 Slide the coupling sleeve (E) up the drive shaft coupling (F) to reveal the coupling pin (G).

3.3.3 Use a piece of rod of suitable diameter to push out the coupling pin (G). (The tip of a ball point pen will suffice!)

3.3.4 Locate the mixing assembly (J) onto the two studs ensuring that the mating surfaces are clean.



Note: Where there is insufficient clearance refer to Para. 5.1 and raise the mixer body.

3.3.5 Refit the knurled nuts (H) with the narrow end positioned against the flange.

3.3.6 Correctly align the drive shaft coupling (F) and shaft and rotor (K) and insert the coupling pin (G).

3.3.7 Slide the coupling sleeve (E) down the coupling until the clip engages into the groove of the coupling thus captivating the coupling pin (G).



CAUTION: FOR THE REMOVAL OF THE MIXING FRAME ASSEMBLIES APPLY THE ABOVE FITTING PROCEDURE IN REVERSE. WHEN REMOVING THE TUBULAR MIXING FRAME ASSEMBLIES CARE SHOULD BE TAKEN WHEN EXTRACTING THE PIN (G) TO SUPPORT THE MIXER FRAME DRIVE SHAFT (K).

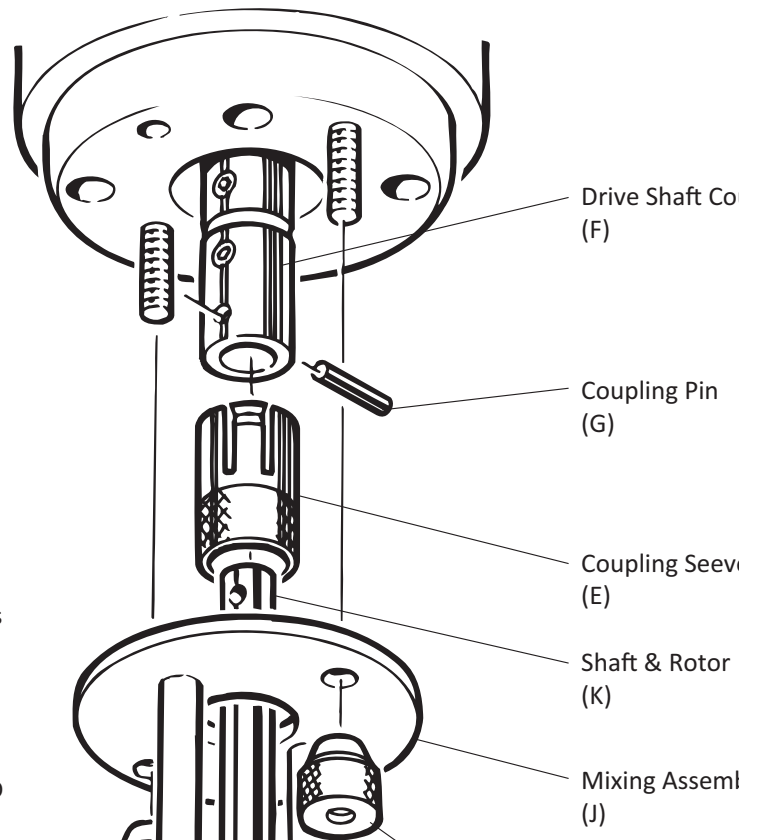

Fig. 2 Fitting The Standard Mixing Assembly

4.0 DESCRIPTION

4.1 GENERAL

The Silverson multifunctional L5M-A laboratory mixer features a powerful 1hp motor, touch screen control with digital tachometer, programmable integral timer and amperage display, all accessed via the control panel. This level of instrumentation is invaluable for applications where process validation and reproducibility are required. The digital display includes motor RPM, ampere rating and timer settings for operations.

The Silverson L5M-A is suitable for the widest range of applications - mixing, emulsifying homogenising, disintegrating, dissolving - with an efficiency and flexibility unmatched by other machines. With a capacity from 1ml up to 12 litres and the ability to mix in-line with flow rates up to 20 litres/minute, it offers excellent reproducibility when scaling up to full scale production and provides an accurate and easy means of forecasting the performance of larger Silverson machines under full-scale working conditions.

Motor -

1 hp (746w), 110 Volt, Maximum Speed 10,000 rpm.
12 max rated amp draw at full load.

Speed Control -

Infinitely variable electronic speed control with integral on/off switch.

Electric Raise & Lower Bench Stand

The mixing unit may be effortlessly raised and lowered using the push-button control on the drive unit.

Construction -

All wetted parts are in grade 316L stainless steel with the exception of the bushing which may be bronze alloy or PTFE. The mixer is finished in a tough, easy to clean, non-chip, white nylon coating. The flat base is covered by a removable non-slip mat which is resistant to most solvents.

The mixer consists of three sub assemblies: the mixer body, the base assembly and the column unit. A selected mixing assembly and head/screen is then attached to the mixer body

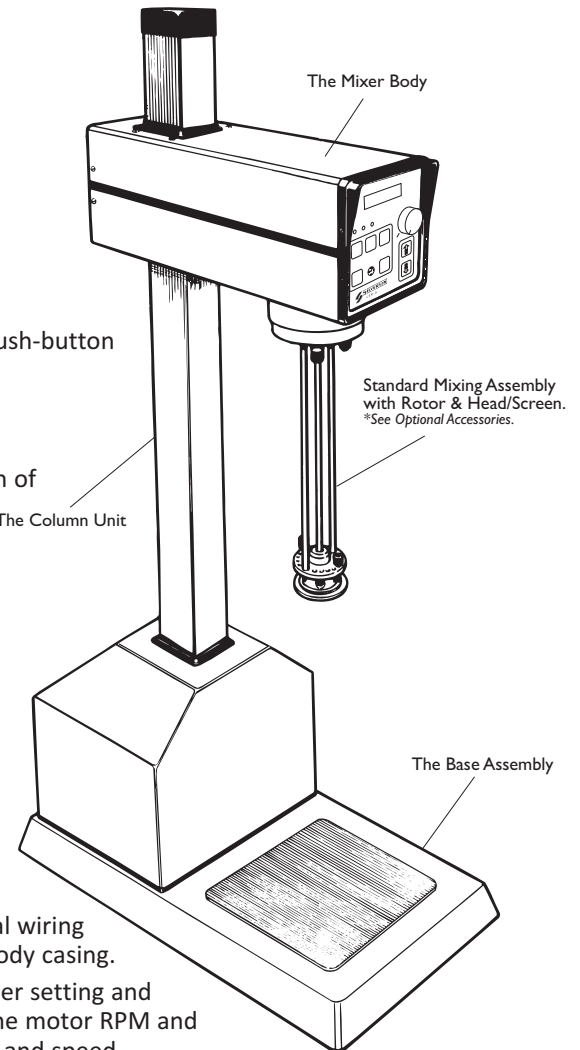

Fig. 3 The L5M-A Mixer Assembly

4.1.1 THE MIXER BODY

The mixer body consists of a lower casing and a top cover to which the rear panel and front control panel are attached. This body is mounted to an enclosed screw shaft assembly which when electrically operated travels vertically up/down the column unit.

The mixer body houses the mixer motor, control units and electrical wiring for these components. Sealing strips and bezels are fitted to the body casing.

The front panel carries push buttons for Raise & Lower control, timer setting and a digital display. The digital display enables the operator to view the motor RPM and ampere rating and the timer settings. The combined on/off switch and speed control will indicate power on by illuminating the green Motor Power light.

4.1.2 THE BASE ASSEMBLY

The base assembly, to which the column unit is mounted, serves as a platform for mixing containers, a removable non-slip mat is also provided.

The Raise & Lower motor and its associated capacitor(s), the rise/fall limit switch, the 'power on' switch with integral safety cut-out device and the electrical wiring for these components are located at the base of the column and housed inside the base cover.

A sealing strip and bezel are fitted to the cover plate to form a splash proof enclosure.



WARNING: THE ENCLOSURE IS NOT WATERPROOF, HOSE PROOF OR WEATHERPROOF.

4.0 Description



4.1.3 THE COLUMN UNIT

The mixer body and the base assembly are connected by the column unit which houses components for the rise/fall mechanism.

4.2 ACCESSORIES

The L5M-A mixer is normally supplied with a standard two arm mixing assembly and a selection of interchangeable heads and screens as shown on FIG. 4. All of the optional accessories described in the following paragraphs are interchangeable with the L5M-A mixer and available as optional extras. Silverson Machines Inc. will be pleased to advise and quote for your specific requirements. When interchanging mixing assemblies please refer to the installation section of this manual for instructions. The Operation section of this manual recommends which head/screen should be used with certain mixing techniques and details how to change the head/screen.

4.3 STANDARD MIXING ASSEMBLY

4.3.1 MIXING ASSEMBLY (FIG. 4)

The standard mixing assembly is of a two arm construction with a central detachable drive shaft and rotor, bush and base plate; the material of the bush will be either bronze alloy or PTFE as per customer specification.

This assembly is supplied complete with a square hole high shear screen, general purpose disintegrating head, diagonal slotted disintegrating head, fine emulsor screen and the pump head. Its mixing capacity, depending upon the product viscosity, is up to 12 litres.

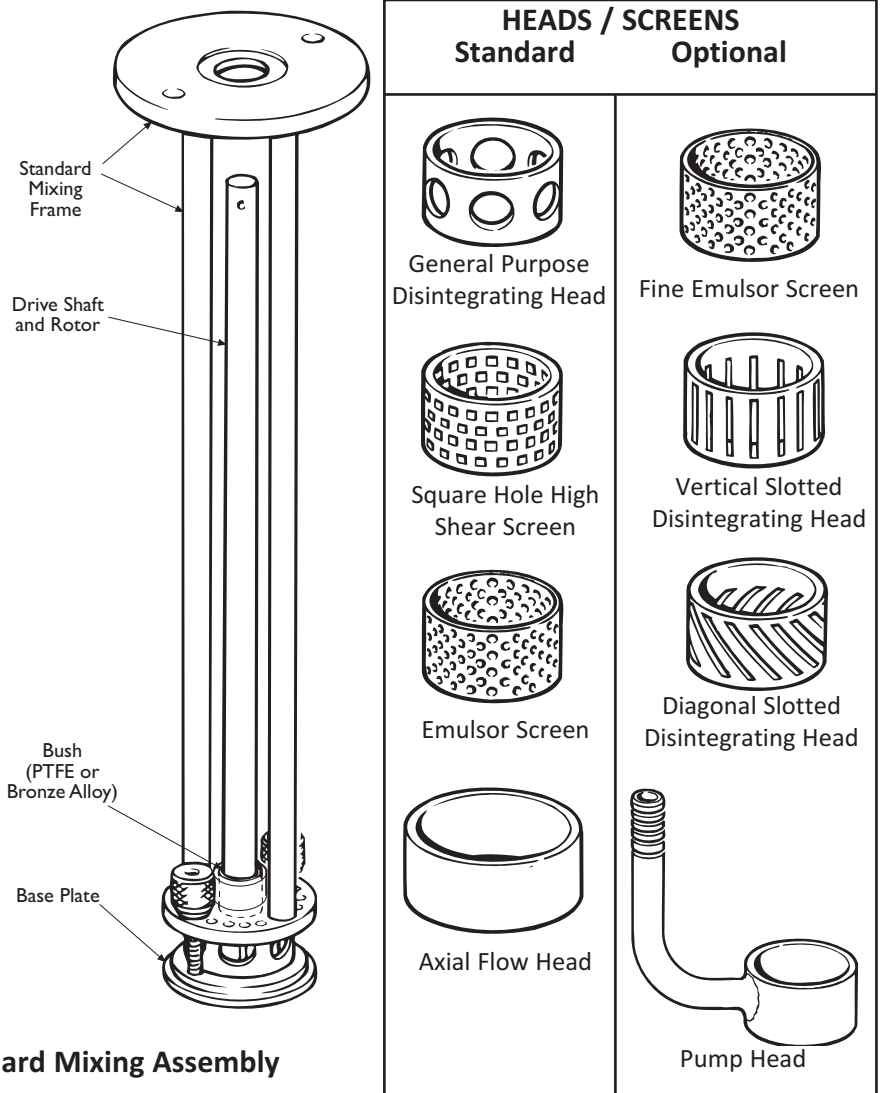

Fig. 4 Standard Mixing Assembly

4.4 HEADS AND SCREENS

A comprehensive range of heads and screens is available for all Silverson High Shear Mixers.

These easily interchangeable heads/screens offer great versatility by allowing the machine to be adapted to perform a wide range of mixing operations. These include emulsifying, homogenising, disintegrating, dissolving, dispersing, blending, particle size reduction and de-agglomerating. Changing from one head or screen to another is quick and simple; refer to the operating section of this Manual for details.

4.4.1 GENERAL PURPOSE DISINTEGRATING HEAD

This is the most versatile of all the heads, giving an exceptionally vigorous mixing action. Ideal for general mixing applications, its uses also include the disintegration of solids and the preparation of gels and thickeners, suspensions, solutions and slurries.

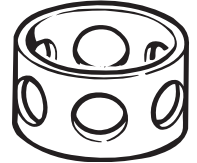

4.4.2 SQUARE HOLE HIGH SHEAR SCREEN

The configuration and fine internal tolerances of this stator provide exceptionally high shear rates which are ideal for the rapid size reduction of soluble and insoluble granular solids. It is also suitable for the preparation of emulsions and fine colloidal suspensions.

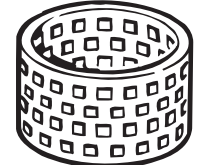

4.4.3 EMULSOR SCREEN

Suitable for liquid/liquid preparations and especially useful for all emulsions. Available in fine and medium (standard) perforations.

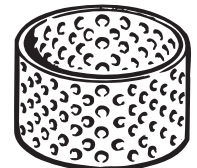

4.4.4 AXIAL FLOW HEAD

This head expels material vertically upwards instead of horizontally and is used in certain circumstances where aeration needs to be minimised. It may also be used to maintain heavy insoluble solids in suspension. Any of the other interchangeable heads and screens (excluding the pumphead) can be fitted inside the Axial Flow Head and used in conjunction with it. Refer to the operating section of this Manual for instructions.

While the Axial Flow Head offers certain benefits in particular circumstances we do NOT recommend that it is used 'as standard'.

Use of the Axial Flow Head may prevent the mixer from being run at high speeds as the upwards vertical flow of material out of this head may throw liquid up and out of the vessel - particularly on low viscosity products or low volumes.

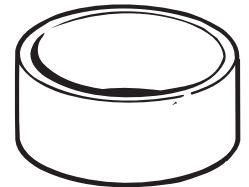

WARNING: WHEN USING THE AXIAL FLOW HEAD ALWAYS START THE MACHINE AT THE LOWEST POSSIBLE SPEED AND INCREASE IT GRADUALLY UNTIL THE DESIRED FLOW PATTERN IS ACHIEVED. HIGH SPEEDS MAY RESULT IN MATERIALS BEING THROWN UP AND OUT OF THE VESSEL. EXCESSIVE SPLASHING AND SPILLAGE MAY OCCUR.

4.4.5 SLOTTED DISINTEGRATING HEAD (OPTIONAL ACCESSORY)

The slotted disintegrating head may be supplied as an optional extra. It is used for the disintegration of fibrous materials such as animal and vegetable tissue, as well as the disintegration and solubilisation of 'elastic' materials such as rubbers and polymers. Vertical and diagonal slotted heads are available.

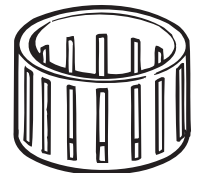
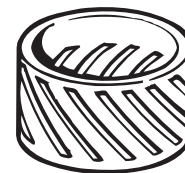

4.4.6 PUMP HEAD (OPTIONAL ACCESSORY)

The pump head converts the mixer into a non-positive pump which with the use of a flexible hose and valve can be used to fill individual containers.

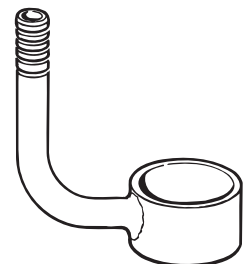

CAUTION: When using the pump head DO NOT allow the mixing vessel to become sufficiently empty for the head and bearing bush to run 'dry'.

4.0 Description



4.5 OPTIONAL ACCESSORIES - TUBULAR MIXING ASSEMBLIES

4.5.1 TUBULAR FRAMES (FIG. 5)

A range of interchangeable tubular mixing units is available as detailed below. The units have capacities from 1-500 ml and are suitable for use in narrow-necked containers.

1" Tubular: Supplied with interchangeable screw-on General Purpose Disintegrating Head and Square Hole High Shear Screen or Integral Open-ended, Vertical Slotted Disintegrating Head for tissue homogenisation. Interchangeable, screw-on Slotted Disintegrating Heads are available as extras.
 Mixing unit outside diameter = 25mm (1"). Overall length = 240mm (9.1/2")

3/4" Tubular: Generally as the 1" above.
 Mixing unit outside diameter = 19mm (3/4"). Overall length = 208mm (8.1/4").
 Length of 3/4" diameter section = 151mm (6").

5/8" Micro: Mixing unit of solid one-piece construction with Integral General Purpose Disintegrating Head or Open-ended, Vertical Slotted Disintegrating Head.
 Mixing unit outside diameter = 16mm (5/8"). Overall length = 160mm (6.1/4").
 Length of 5/8" diameter section = 102mm (4").

3/8" Mini-Micro: Generally as 5/8" Micro above.
 Mixing unit outside diameter = 10.3mm (1.3/32"). Overall length = 119mm (4.11/16").
 Length of 5/8" diameter section = 62mm (2.7/16").

| | 1" Tubular | 3/4" Tubular | 5/8" Micro | 3/8" Mini-Micro |
|--|------------------|------------------|----------------|-----------------|
| CAPACITY - Depending on Viscosity | 50ml up to 500ml | 20ml up to 250ml | 5ml up to 50ml | 1ml up to 10ml |

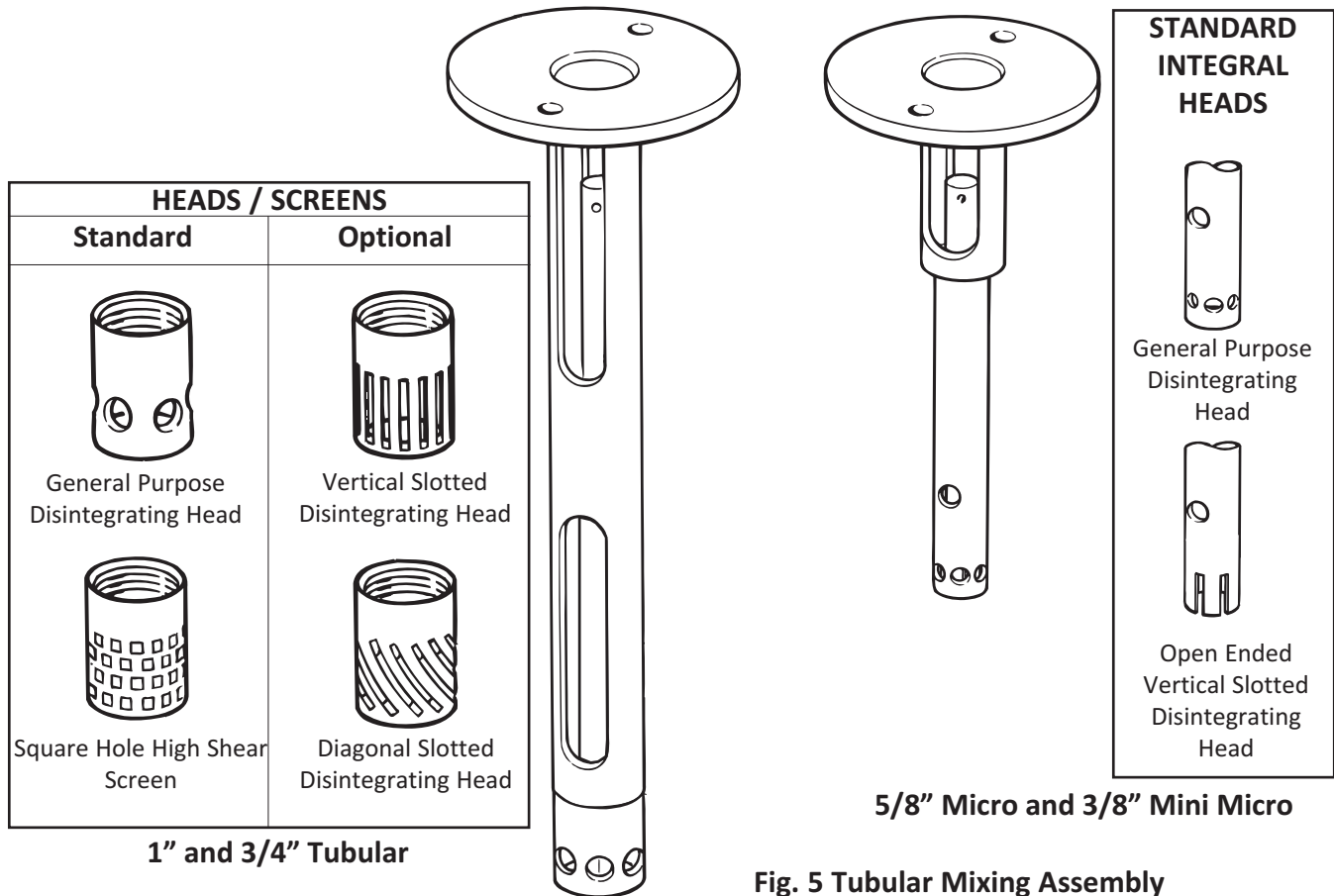

Fig. 5 Tubular Mixing Assembly

4.6 OPTIONAL ACCESSORIES - LABORATORY IN-LINE MIXING ASSEMBLY

4.6.1 Laboratory In-Line Mixing Assembly (FIG. 6)

The In-Line assembly fits on to the L5M-A mixer and converts it into an In-Line mixer/homogeniser. The centrifugal action of the rotor in the high shear head/screen generates a non-positive pumping action which gives a throughput on water viscosity liquids of approximately 20 litres/minute, reducing as the viscosity increases. The pumping rate can be lowered by reducing the motor speed but it is better to insert a valve in the pipeline on the outlet side as reducing the speed also reduces the mixing efficiency.

The unit is suitable for use at atmospheric pressure only. It is not recommended for use on abrasive, corrosive or flammable materials.

Construction: All product contact parts in 316L stainless steel except the bush (PTFE or bronze alloy) and mechanical shaft seal (carbon/stainless steel with viton elastomers) and the viton body 'O' rings.

Supplied complete with General Purpose Disintegrating Head and Square Hole High Shear Screen.

Options:

- Slotted Disintegrating Head and Emulsor Screens (fine and medium perforations).
- Seal elastomers and body 'O' ring available in Kalrez/PTFE.

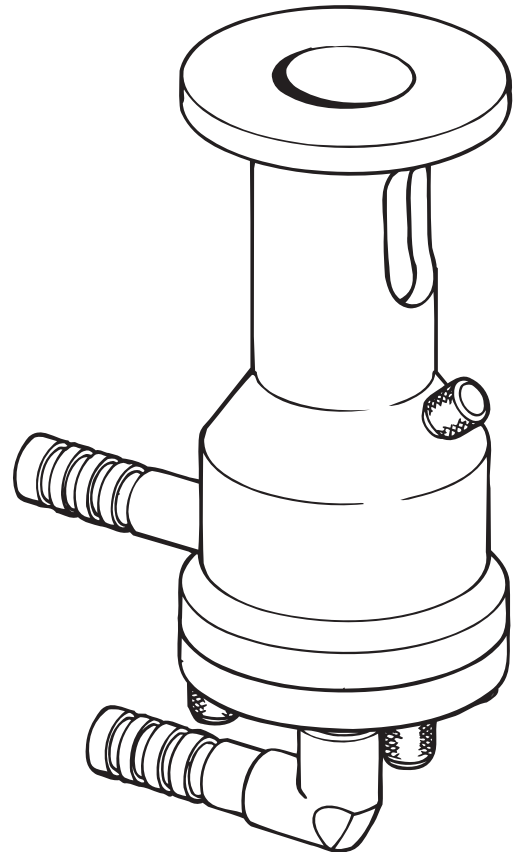
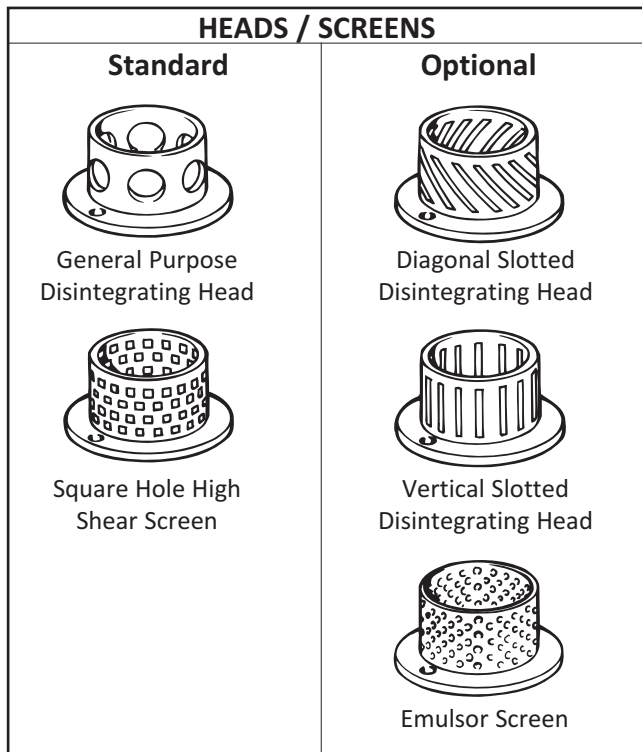

Fig. 6 Laboratory In-Line Mixing Assembly

4.0 Description



4.7 OPTIONAL ACCESSORIES - LABORATORY DUPLEX MIXING ASSEMBLY

4.7.1 Laboratory Duplex Mixing Assembly (Fig. 7)

The Duplex differs from the standard mixing assembly in having two heads facing in opposite directions; the upper head pulls materials down from the surface of the mix, while the lower head/screen draws material up from the base of the mixing container. The upper Coarse Tooth Disintegrating Head is designed to chop solid materials into small pieces and then expel them beneath the shroud. The lower head/screen simultaneously draws in these partially disintegrated solids and reduces their size further.

The combined use of two heads makes the Duplex ideal for applications where light or buoyant material (powders, rubbers and polymers, etc.) needs to be drawn down from the surface of a mix and rapidly dispersed. Because of the movement afforded by the two heads, the Duplex is also ideal for use on high viscosity materials. Supplied complete with upper Coarse Tooth Disintegrating Head and lower General Purpose Disintegrating Head

Options:

- Lower Slotted Disintegrating Heads, Square Hole High Shear Screen, Emulsor Screens and upper General Purpose Disintegrating Head.

Typical Applications:

- Rapid solution of rubbers and polymers into lubricating oils, non-flammable solvents and asphalt for the production of luboils, adhesives and bituminous compounds.
- Disintegration and dissolving solid resin for the production of varnish.
- Addition of powders into high viscosity liquids.
- Vegetable and meat purée/slurries

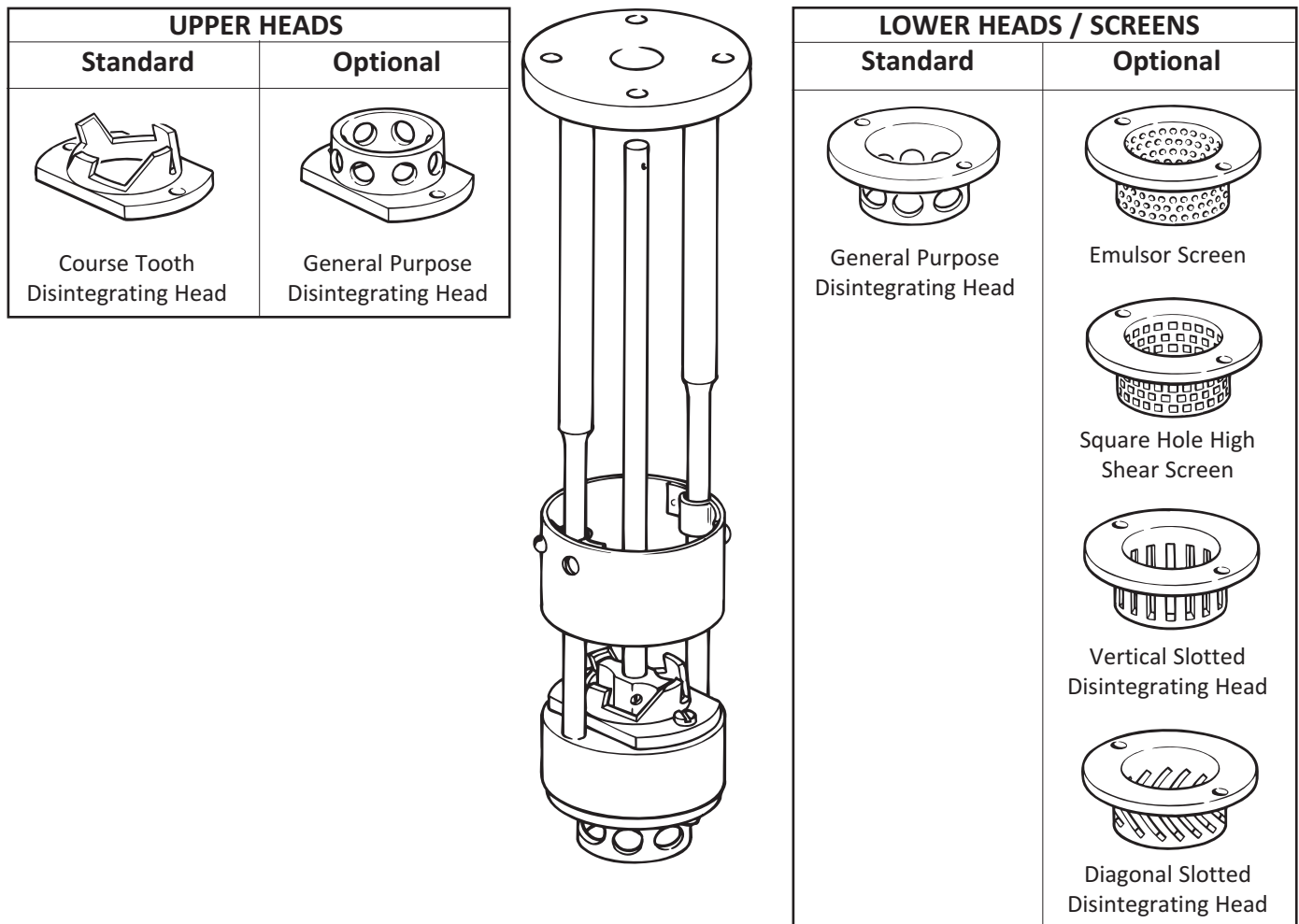

Fig. 7 Laboratory Duplex Mixing Assembly

5.1 OPERATION (Refer to Fig. 8)



CAUTION: The mixer frame must always be immersed so that fluid covers the entire working head/screen and the bearing bush BEFORE the machine is switched on at all times during operation. If this precaution is not taken overheating and seizure of the shaft will result. NEVER allow the machine to run “dry”. The manufacturer will not accept responsibility for damage if this precaution is not observed.



CAUTION: Before starting the mixer ensure that the knurled nuts retaining the mixer frame are tight and fitted correctly, ie. with the narrow end positioned against the flange.



CAUTION: Where the mixer is to be used in high ambient temperatures or to mix a very hot product (over 100°C) a cold air supply to the Mixer Body is recommended in order to cool the mixer motor. Contact Silverson Machines Inc. for advice.



WARNING: DO NOT USE THE MACHINE IN A HAZARDOUS AREA WHERE A FLAMMABLE OR EXPLOSIVE ATMOSPHERE MAY BE PRESENT. THIS MACHINE IS NOT EXPLOSION PROOF / FLAME PROOF.



WARNING: BEFORE STARTING THE MIXER ALWAYS ENSURE THAT THE SHAFT COUPLING SLEEVE IS IN ITS CORRECT OPERATING POSITION AND THAT THE COUPLING PIN IS CAPTIVATED BY THE SLEEVE AS SHOWN.



WARNING: NEVER TOUCH ROTATING PARTS. FAILURE TO OBSERVE THIS WARNING MAY RESULT IN BODILY INJURY.

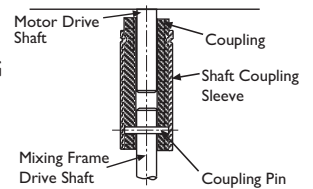

5.1.1 Ensure that the combined on/off switch and speed control knob (A) is in the OFF position (turned fully anti-clockwise and before the ‘MIN’ line on the control panel (B)).

5.1.2 Connect the power supply to the mixer and switch the power on by operating the switch located at the rear of the base assembly, the digital display unit (C) will become illuminated.

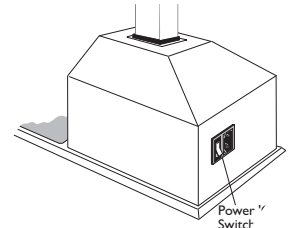

5.1.3 Lower the mixer frame into a vessel containing sufficient liquid so that the entire working head/screen and bearing bush are immersed by operating the Raise & Lower control buttons (D).



WARNING: IF VESSEL BOTTOM IS HIGHER THAN THE BASE PLATFORM, DO NOT ALLOW THE MIXER ASSEMBLY TO STRIKE THE VESSEL BOTTOM WHEN LOWERING.

5.1.4 Turn the control knob (A) clockwise from the OFF to the MIN position (the motor power indicator light will become illuminated). **Gradually** turn the control knob clockwise to increase the speed until a vortex appears in the liquid. The upper line of the digital display unit (C) will display the actual speed of the mixer in RPM (revolutions per minute) and the set speed on the upper RH side. The lower line of the digital display unit will show the current consumption in AMPS.



WARNING: SPILLAGE MAY OCCUR IF THE MIXING SPEED IS INCREASED TOO QUICKLY (SEE TO FIG. 9A).

5.1.5 The mixer speed can be set during operation by turning the control knob (A) to the desired speed. The Mixer will now automatically adjust the power output to maintain the set speed as ingredients are added. The timer controls (E) can be used in conjunction with the speed setting as described below.

5.1.6 The mixer can be programmed to run to a set time if required by setting the timer controls (E). Turn the On/Off switch and speed regulator (A) to the OFF position. Set the timer by pressing the timer control buttons (F) as required to set the mixing time, the time can be set in 1 second increments up to 99 minutes and 59 seconds. The set time will be displayed in the bottom RH area of the digital display unit (C). The timer will start to count down as soon as the mixer is started by turning the switch (A) clockwise to the MIN position.

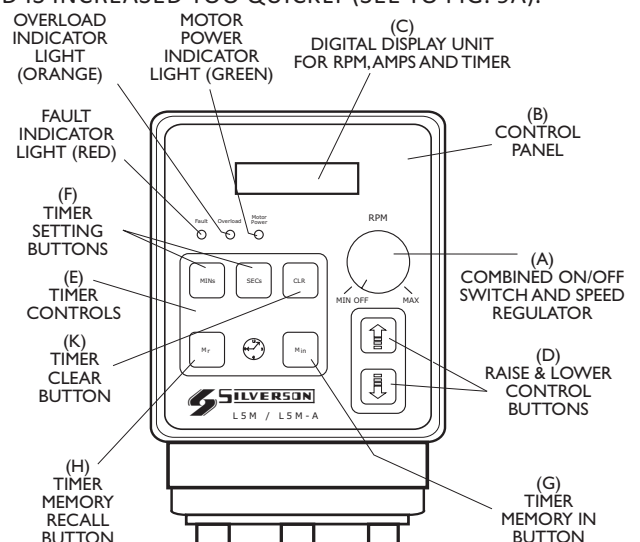

Fig. 8 Operating The LSM-A Mixer Assembly

Mixing times can be preset by pressing the 'M in' (memory in) button (G) which will save the time value to memory. To repeat the preset time press the 'Mr' (memory recall) button (H).

The timer setting can be cancelled or changed while the mixer is running by pressing clear button (K) or the timer control buttons (F). During operation the timer can be paused by turning the combined On/Off switch and speed regulator (A) to the OFF position. The timer will resume counting when the switch is turned back to the MIN position.



CAUTION: If the mixer time is cleared while counting up during operation the time will reset to zero and the mixer will continue to operate and start counting up again until it is manually switched off by turning the combined ON/OFF switch and speed regulator (A) to the OFF position.



CAUTION: If there is no time set, the timer will count up when the mixer is in the operating position (MIN or above). If the mixer time is cleared while counting down (from a preset time), the mixer will stop.

5.1.7 Should the electrical supply to the mixer be interrupted or surge at any time the mixer incorporates a safety device which will automatically cut the power to the mixer motor. This is to prevent accidents occurring should the electrical supply be re-connected while the mixer operator is unaware. Once the power is resumed reset the mixer by turning the combined ON/OFF switch and speed regulator (A) off and back on again.

5.1.8 The maximum mixing viscosity will depend on the product rheology.

5.1.9 Full load amp draws:

The motor maximum full load amp draw of the L5M-A Mixer is:

12 amps, 110V motor, 10,000 RPM - Optional



CAUTION: Continuous running above 12amps will result in the motor stopping and an overload fault will be displayed.



Note: AFTER THE MIXER HAS BEEN TURNED OFF, THE INTEGRAL FAN WILL CONTINUE TO RUN UNTIL THE MOTOR HAS COOLED.

5.2 GENERAL GUIDELINES FOR MIXING (Refer to Figs. 9a & 9b)

The following guidelines are designed to help you get the best results from your Silverson mixer. Due to the vast range of mixing operations for which your mixer can be used, it is impossible to cover every eventuality and the ideal mixing technique for your particular product will probably only be found after some experimentation. Should you require further advice then please contact Silverson Machines or their accredited agents who will be happy to help you achieve your required mixing results.

5.2.1 Positioning The Head/Screen

The position of the head/screen within the vessel can affect the mixing performance of the machine. The recommended initial position is slightly off centre with the head/screen approximately 2.5-5 cms (1"-2") off of the bottom of the vessel (Fig 9b).

A centrally positioned head/screen (Fig. 9a) results in a deeper vortex and may cause aeration, splashing or spillage in less viscous mixes. Moving the head/screen off centre (Fig 9b) produces a smaller vortex enabling the mixer to operate at higher speeds without splashing or spillage.

The mixer head/screen can be raised or lowered to assist the movement of the surface liquid as the viscosity increases or decreases.

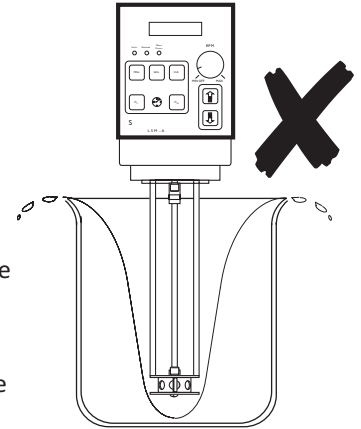

Fig. 9a Mixing Techniques



WARNING: SPILLAGE MAY OCCUR IF THE MIXING SPEED IS INCREASED TOO QUICKLY. (FIG. 9A)

5.2.2 Setting The Speed

Generally, the mixer should be run at the highest speed possible without causing excessive aeration, splashing or spillage. High speeds will give faster mixing times and the best end-results in terms of particle or globule size reduction. Reducing the speed reduces the mixing efficiency.



WARNING: DO NOT USE THE MACHINE IN A HAZARDOUS AREA WHERE A FLAMMABLE OR EXPLOSIVE ATMOSPHERE MAY BE PRESENT. THIS MACHINE IS NOT EXPLOSION PROOF / FLAME PROOF.

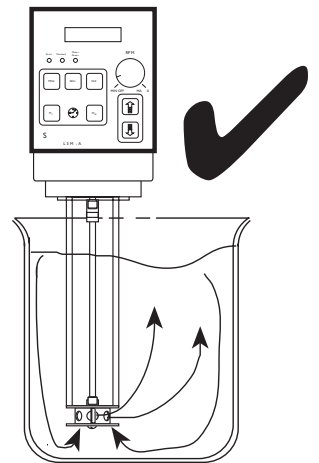

Fig. 9b Mixing Techniques

5.3 DISINTEGRATING LARGE SOLIDS & AGGLOMERATES INTO LIQUIDS



NOTE: If the particle size of the solids is too large for the standard mixing assembly they should be reduced in size prior to mixing. Alternatively, using a *Duplex mixing assembly could be considered.



RECOMMENDED head/screen: General Purpose Disintegrating Head or Slotted Disintegrating Head (optional extra). *See also the Duplex Mixing Assembly.

- A: Lower mixing assembly into the liquid
- B: Turn machine on
- C: Increase speed to maximum without splashing
- D: Ensure you have a suitable flow pattern
- E: Add solids quickly but in a controlled manner. NB: Avoid pouring the solids onto the metal parts
- F: Increase speed as the viscosity increases
- G: Run until desired end-result is achieved

5.4 DISPERSING POWDERS INTO LIQUIDS

(See also Duplex mixing assembly)



RECOMMENDED head/screen: *General Purpose Disintegrating Head or Square Hole High Shear Screen if particle size reduction is required.*

Method is as 5.3 above.

5.5 SMALL SOLID PARTICLE SIZE REDUCTION



RECOMMENDED head/screen: *Square Hole High Shear Screen*

Method is as 5.3 above.

5.6 DISINTEGRATING SOLIDS INTO LIQUIDS



RECOMMENDED head/screen: *General Purpose Disintegrating Head or Square Hole High Shear Screen . *See also the Duplex Mixing Assembly.*

Method is as 5.3 above.

5.7 BLENDING



RECOMMENDED head/screen: *General Purpose Disintegrating Head*



NOTE: *Add higher viscosity liquid into lower viscosity liquid where practical.*

- A: Lower mixing assembly into the liquid
- B: Turn machine on
- C: Increase speed to maximum without splashing
- D: Ensure you have a suitable flow pattern
- E: Add liquids quickly but in a controlled manner
- F: Increase speed as the viscosity increases
- G: Run until desired end-result is achieved

5.8 DISPERSING GUMS & THICKENERS

(See also Duplex mixing assembly)



RECOMMENDED head/screen: *General Purpose Disintegrating Head or Square Hole High Shear Screen.*

- A: Lower mixing assembly into the liquid
- B: Turn machine on
- C: Increase speed to maximum without splashing
- D: Ensure you have a suitable flow pattern
- E: Add gums & thickeners quickly but in a controlled manner. Do not add them slowly. NB: Avoid pouring the solids onto the metal parts
- F: Increase speed as the viscosity increases

5.9 EMULSIONS



RECOMMENDED head/screen: Square Hole High Shear Screen or Emulsor Screen. Fine Emulsor Screen - optional extra.

NOTE: Common emulsions are either oil into an aqueous phase or an aqueous phase into oil. An emulsification agent is required in order to produce a stable product.

- A: Lower the mixing assembly into the continuous phase (water for an oil in water emulsion or oil for a water in oil emulsion).
- B: Turn machine on
- C: Increase speed to maximum without splashing
- D: Ensure you have a suitable flow pattern
- E: Add suspended phase (oil for an oil in water emulsion or water for a water in oil emulsion)
- F: Increase speed as the viscosity increases
- G: Run until desired end-result is achieved
- H: The longer the mixer operates the more uniform the suspended particle size will be

5.10 TISSUE HOMOGENISATION



USE: Tubular mixing assembly with integral open ended Slotted Disintegrating Head

- A: Add solids into liquid
- B: Raise mixing container up to the mixing assembly
- C: Ensure mixing assembly is submerged in the liquid
- D: Position solids so they are at the base of the mixing assembly - just below the Slotted Disintegrating Head teeth
- E: Turn machine on
- F: Increase speed to maximum without splashing
- G: Run until desired end-result is achieved

5.11 TUBULAR MIXING ASSEMBLY



OPERATION as Standard Mixing Assembly.

5.12 LABORATORY DUPLEX MIXING ASSEMBLY

- 5.12.1 The Duplex differs from the standard mixing assembly in having two heads facing in opposite directions; the upper head pulls materials down from the surface of the mix, while the lower head/screen draws material up from the base of the mixing container.

The upper Coarse Tooth Disintegrating Head is designed to chop solid materials into small pieces and then expel them beneath the shroud. The lower head/screen simultaneously draws in these partially disintegrated solids and reduces their size further.

This combined use of two heads makes the Duplex ideal for applications where light or buoyant material (powders, rubbers and polymers, etc.) needs to be drawn down from the surface of a mix and rapidly dispersed. The added movement afforded by the two heads makes the Duplex ideal for use on high viscosity materials.

5.12.2 Typical Applications:

- Rapid solution of rubbers and polymers into lubricating oils, non flammable solvents and asphalt for the product of luboils, adhesives and bituminous compounds.
- Disintegration and dissolving solid resin for the production of varnish.
- Vegetable and meat purée/slurries.
- Addition of powders into high viscosity liquids.

5.0 Operation



5.13 IN-LINE MIXING ASSEMBLY



NOTE: The In-Line Mixing Assembly is suitable for use at atmospheric pressure only. Product should be pumped into an open vessel.



CAUTION: The In-Line mixing chamber must always be filled so that fluid covers the entire working head/screen and the bearing bush BEFORE the machine is switched on. If this precaution is not observed overheating and seizure of the shaft will result. NEVER allow the machine to run “dry”. The manufacturer will not accept responsibility for damage if this precaution is not observed.

- A: Connect the suction tubing (minimum of 1/2” I.D.) to the bottom inlet and clamp tightly. This connection must be air tight to avoid introducing air into the fluid mixture and to prevent breaking the suction flow of the mixing chamber. Connect similar discharge hose of sufficient length and diameter to the outlet.
- B: Fill the quench cup with sufficient coolant/lubricating fluid to cover the seal elements.

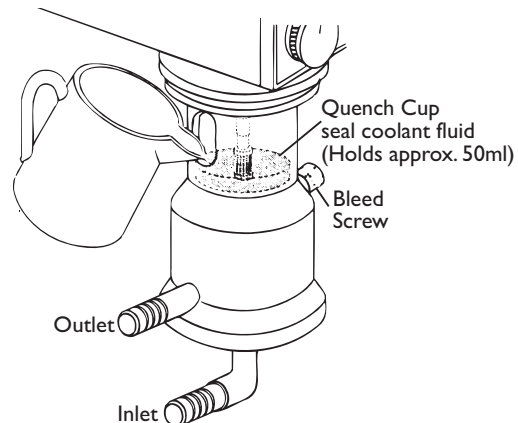

NOTE: A fluid compatible to that being mixed should be used.

- C: Best results are obtained using a beaker/vessel with a side/bottom outlet as a supply vessel.
- D: Ensure liquid level in the supply beaker/vessel is above the level of the In-line assembly
- E: Open bleed screw on the top right side of the mixing chamber to vent air while filling the suction line and mixing chamber.
- F: Check that the coupling pin and sleeve are in place. Rotate the shaft by hand to ensure that everything rotates freely.
- G: Turn mixer on and increase speed to maximum.
- H: Ensure satisfactory circulation. You may want to install a flow control valve on the discharge side of the mixer to control the rate of flow and processing.



CAUTION: Do not add a control valve to the the supply side.

- I: Add additional ingredients either directly into the beaker/vessel or into the In-line mixer assembly inlet by means of a laboratory pump.



NOTE: High viscosity materials can be mixed by using a laboratory pump to feed them into the In-line mixer assembly.

5.14 CLEANING

5.14.1 The L5M-A mixer is in most cases self cleaning, a short run between successive mixing operations in water, detergent or an appropriate non-flammable solvent should be all that is necessary to clean the wetted parts. For more thorough cleaning, dismantling is easy and downtime minimal.

5.14.2 The housing and wetted parts can be cleaned with household cleaning agents providing that they do not contain solvents and are non-scratching. Do not scour the parts with sharp objects.



WARNING: IF IT IS NECESSARY TO USE FLAMMABLE SOLVENTS TO CLEAN MIXED PRODUCT OFF THE WETTED PARTS, THEN THE MIXING ASSEMBLY MUST BE REMOVED AND CLEANED IN A SAFE AREA, AWAY FROM THE MACHINE.



WARNING: THE MACHINE SHOULD NEVER BE SPRAYED WITH WATER OR IMMERSED IN WATER.

5.15 CHANGING THE HEAD / SCREEN - STANDARD MIXING ASSEMBLY

5.15.1 It is not necessary to remove the mixing assembly from the mixer body in order to interchange the heads or screens.

5.15.2 Unscrew the knurled nuts and remove the base plate complete with the head/screen from the bearing plate.



WARNING: THE ROTOR BLADES MAY BE SHARP.

5.15.3 Exchange the head/screen as required.

5.15.4 Refit the base plate complete with the head/screen to the bearing plate and refit the knurled nuts.



CAUTION: When fitting a head/screen, note that there is a step or register in the underside face of the bearing plate and the upper face of the base plate. It is important that both these surfaces and the edges of the replacement head / screen are clean and free of solid or dissolved materials. If cleanliness is not observed, the head / screen will not seat squarely and may foul the rotor.

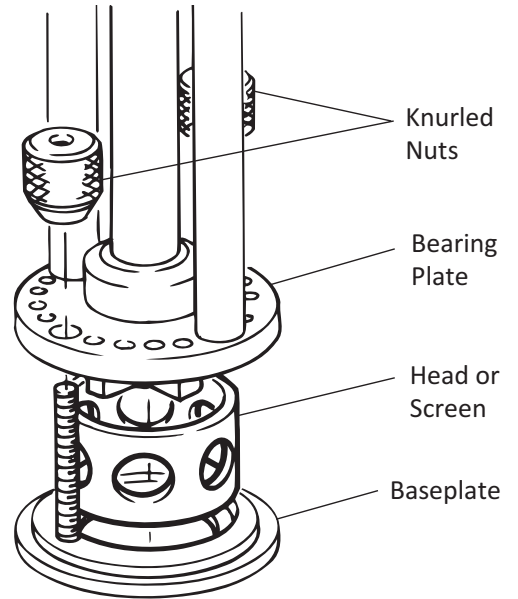

Fig. 10 Changing the Head of the Head/Screen of the Standard Mixing Assembly

5.16 FITTING THE AXIAL FLOW HEAD TO THE STANDARD MIXING ASSEMBLY

5.16.1 It is not necessary to remove the mixing assembly from the mixer body in order to fit the axial flow head.

5.16.2 Unscrew the knurled nuts and remove the base plate complete with the head/screen from the bearing plate.



WARNING: THE ROTOR BLADES MAY BE SHARP.

5.16.3 Exchange the head/screen as required, locating it onto the inner register of the base plate.

5.16.4 Fit the axial flow head onto the outer register of the base plate.

5.16.5 Refit the base plate complete with the head/screen (as required) and the axial flow head to the bearing plate and refit the knurled nuts.



CAUTION: When fitting a head/screen, note that there is a step or register in the underside face of the bearing plate and the upper face of the base plate. It is important that both these surfaces and the edges of the replacement head/screen are clean and free of solid or dissolved materials. If cleanliness is not observed, the head / screen will not seat squarely and may foul the rotor.

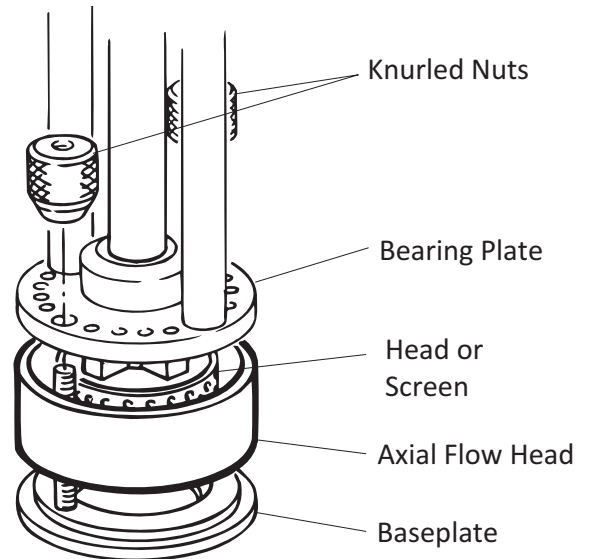

Fig. 11 Fitting the Axial Flow Head

NOTES:

1. The axial flow head is usually used in conjunction with a screen or disintegration head depending on the nature of the application.

2. If the axial flow circulation pattern is not required the axial flow head should be removed and processing carried out only with the appropriate head or screen.

*3. When the axial flow head is in use the motor speed should be reduced to a minimum when starting and gradually increased until the upward streams of liquid are just breaking the surface.

***WARNING:** SEVERE AND POSSIBLY DANGEROUS SPILLAGE MAY OCCUR IF THIS PRECAUTION IS NOT TAKEN.



OPTIONAL ACCESSORIES:

5.17 CHANGING THE HEAD / SCREEN - TUBULAR MIXING ASSEMBLY

NOTE: Heads / screens can only be interchanged on certain 1" and 3/4" Tubular frames.

5.17.1 It is not necessary to remove the frame from the mixer body in order to interchange the heads or screens.

5.17.2 The head / screen is removed by unscrewing from the base of tubular frame.

NOTE: The tubular frames have a left hand thread (To remove head/screen rotate in a clockwise direction when viewed from below)

WARNING: THE ROTOR BLADES AND HEAD/SCREEN MAY BE SHARP.

5.17.3 An alternative or replacement head / screen is fitted by reversing the above procedure.

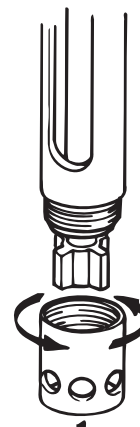

Fig. 12 Changing the Head / Screen - Tubular Mixing Assembly

5.18 CHANGING THE HEAD / SCREENS - LABORATORY DUPLEX MIXING ASSEMBLY

THE LOWER HEAD / SCREEN See Fig. 13

5.18.1 It is not necessary to remove the duplex mixing assembly (1) from the mixer body in order to interchange the lower head/screen.

5.18.2 While supporting the head/screen, evenly unscrew the two slotted head screws (10) from the bearing housing and carefully lower the head/screen down over the lower rotor.

WARNING: THE ROTOR BLADES ARE SHARP.

5.18.3 An alternative lower head/screen is fitted by reversing the above procedure ensuring that the mating faces of the head/screen and bearing housing are clean.

CAUTION: When fitting a head/screen it is important that mating surfaces are clean and free of solid or dissolved materials. If cleanliness is not observed, the head / screen will not seat squarely and may foul the rotor.

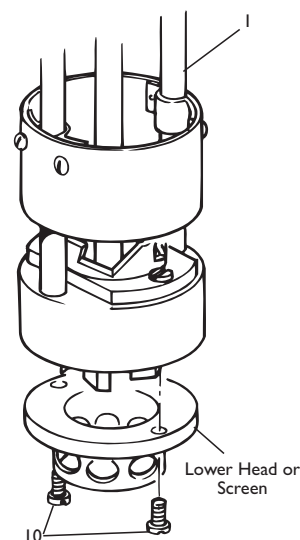

Fig. 13 Changing the Lower Head / Screen - Duplex Mixing Assembly

THE UPPER HEAD See Fig. 14

5.18.4 To remove the upper head the duplex mixing assembly (1) must be detached from the mixer body - refer to the installation section of this Manual.

5.18.5 If the location of the shroud (7) obstructs the removal of the head slacken the four screws (9) and carefully slide the shroud up the frame (1). Re-tighten the four screws to retain.

NOTE: It may be useful to note the position of the shroud (7) prior to moving it.

5.18.6 Slacken the two grub screws which retain the upper rotor to the drive shaft and withdraw the shaft through the bearing plate. Take care to retain the upper rotor once it is disengaged from the shaft.

5.18.7 Evenly unscrew the two slotted head screws (10) from the bearing housing and carefully raise and withdraw the head from the frame (1).

5.18.8 An alternative upper head is fitted by reversing the above procedure ensuring that the mating faces of the head and bearing housing are clean.

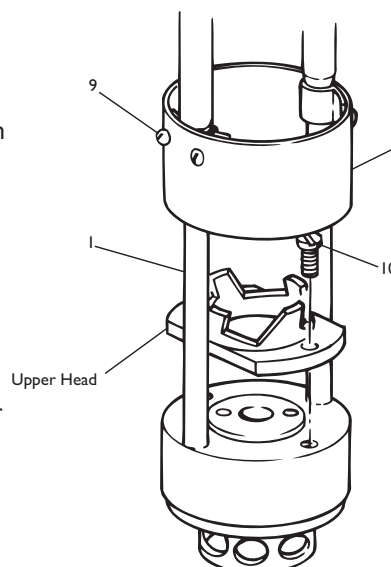

Fig. 14 Changing the Upper Head / Screen - Duplex Mixing Assembly

- 5.18.9 Refit the drive shaft and upper rotor ensuring that the rotor is correctly positioned and secured firmly by the two retaining grub screws.
- 5.18.10 Re-position the shroud (7) if previously moved or displaced.
- 5.18.11 Refit the duplex mixing assembly (1) to the mixer body - refer to Para. 4.3



CAUTION: When fitting a head it is important that mating surfaces are clean and free of solid or dissolved materials. If cleanliness is not observed, the head / screen will not seat squarely and may foul the rotor.

5.19 CHANGING THE HEAD / SCREEN - IN-LINE MIXING ASSEMBLY

- 5.19.1 It is not necessary to remove the In-Line unit from the mixer body in order to interchange the head/screen.
- 5.19.2 While supporting the stator mounting plate (6) remove the four knurled nuts (8)
- 5.19.3 Carefully lower the mounting plate (6) vertically to avoid the head/ screen striking the rotor blades.
- 5.19.4 Remove the two cap head screws (10) retaining the head/ screen to the mounting plate (6).
- 5.19.5 Exchange the head/screen as required.
- 5.19.6 Inspect the 'O' ring (7) for wear and replace if necessary.
- 5.19.7 Reassemble the in-line unit by applying the above removal procedure in reverse.



CAUTION: When fitting a head/screen, note that there is a step or register in the underside face of the mounting plate (6). It is important that these surfaces and the edges of the replacement head / screen are clean and free of solid or dissolved materials. If cleanliness is not observed, the head / screen will not seat squarely and may foul the rotor.

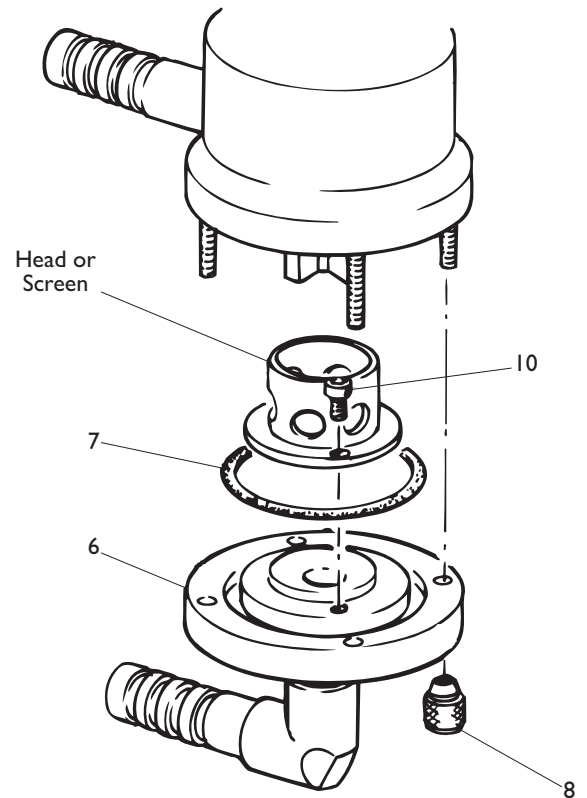

Fig. 15 Changing the Lower Head / Screen - in-Line Mixing Assembly

6.0 MAINTENANCE PROCEDURES

 **WARNING:** ALWAYS ISOLATE THE MACHINE FROM THE ELECTRICAL SUPPLY BEFORE PERFORMING MAINTENANCE PROCEDURES.

6.1 REPLACING THE BUSH

All mixing assemblies have a bush (bronze alloy or PTFE). This bearing bush is lubricated and cooled by the product being mixed. During operation the entire workhead/screen and bearing bush must always be immersed in the fluid being mixed. Failure to do so will result in rapid overheating and seizure of the shaft.

The bush is a wearing part which needs to be replaced at periodic intervals depending on the characteristics of the mix.

The bush must be regularly inspected for signs of wear and replaced when necessary. Where there is any perceptible movement of the shaft within the bush, the bush should be replaced.

 **CAUTION:** Failure to replace the bush when required will cause considerable damage to the Mixer.

 **NOTE:** Prior to carrying out the following instructions the mixing assembly must be disassembled and the drive shaft and rotor removed; specific instructions for the disassembly of each of the mixing assembly are given in the following paragraphs. Turn the mixing frame thro' 180° so that the bearing plate is uppermost.

PTFE BUSH

6.1.1 The PTFE bush is a press-fit and can be easily prized out or pushed into the bearing plate.

BRONZE ALLOY BUSH

6.1.2 Insert the *tool into the bush so that the shoulder of the tool seats squarely onto the face of the bush. Using a soft head (ie. rubber or hide) mallet tap the *tool through the bearing plate until the bush is clear of the housing. Take extreme care not to strike or scratch the mixing assembly.

6.1.3 Fit the replacement bronze alloy bush over the *tool and position the bush so that the leading, tapered edge is against the hole of the bearing plate. Using a soft head (ie. rubber or hide) mallet tap the bush squarely into position taking great care not to strike or scratch the mixing assembly. It is imperative that the bush is fitted squarely into the bearing plate.

 **CAUTION:** If the bush is not straight as it begins to enter the bearing plate remove it and discard; the bush may not straighten itself as it is tapped fully home and will result in more serious damage due to the shaft not running true.

* Silverson Machines Tool Part Number SD505 (Standard)

* Silverson Machines Tool Part Number SD519 (3/8" Mini Micro Mixing Assembly only)

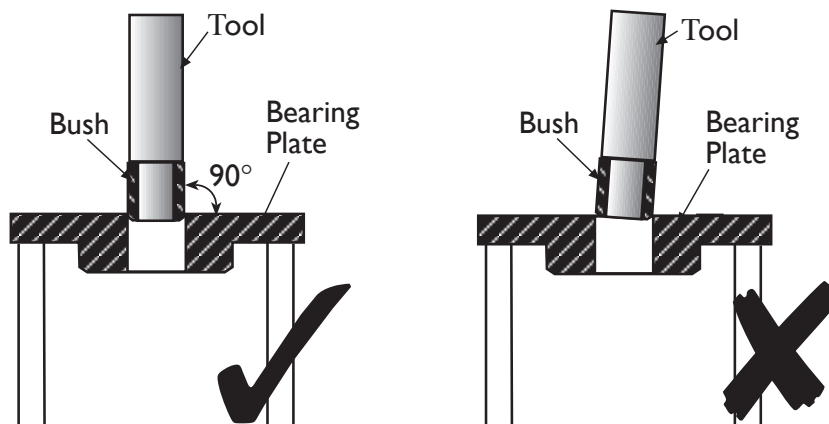

6.2 REPLACING THE BUSH - STANDARD MIXER ASSEMBLY

6.2.1 With the mixing assembly removed from the mixer unscrew the knurled nuts (6), remove the base plate (5) complete with the head/screen from the bearing plate.



WARNING: THE ROTOR BLADES MAY BE SHARP.

6.2.2 The drive shaft and rotor (2) can now be withdrawn from the frame through the bearing plate.

6.2.3 Remove and fit a replacement bush (3 or 4) with reference to Paragraph 6.1.

6.2.4 Refit the drive shaft and rotor (2) into the mixing assembly.



NOTE: Inspect the condition of the drive shaft and rotor assembly (2) ; a replacement assembly should be fitted if there are signs of wear or damage.

6.2.5 Refit the base plate (5) complete with the head/screen to the bearing plate and refit the knurled nuts (6).



CAUTION: When fitting a head/screen, note that there is a step or register in the underside of the bearing plate and the upper face of the base plate (5). It is important that both these surfaces and the edges of the replacement head / screen are clean and free of solid or dissolved materials. If cleanliness is not observed, the head / screen will not seat squarely and may foul the rotor.

6.2.6 Refit the mixing frame to the mixer body (Ref. to Para. 3.3)

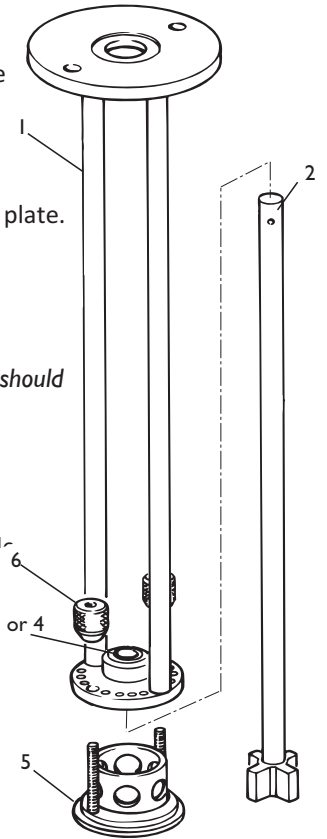

Fig. 16 Replacing the Bush of the Standard Mixing Assembly

6.3 REPLACING THE BUSH OF THE 1", 3/4" and 5/8" TUBULAR MIXING ASSEMBLIES

6.3.1 Remove the head / screen from the tubular frame (1). (Refer to Para. 5.17)

6.3.2 Remove the tubular mixing assembly from the mixer body taking extra care to support the shaft and rotor (2) upon removal of the coupling pin. (Refer to Para. 3.3)



WARNING: THE ROTOR BLADES MAY BE SHARP.

6.3.3 The drive shaft and rotor (2) can now be withdrawn from the mixing assembly through the bush (3 or 4).

6.3.4 PTFE BUSH

The PTFE bush (3) is a press-fit and can be easily prized out or pushed into the bearing plate.

BRONZE ALLOY BUSH

Remove the existing bronze alloy bush (4) by inserting a bar of suitable diameter through the top of the mixing frame (1) and carefully tapping the bush clear, take care not to strike or scratch the mixing assembly.

Fit the replacement bronze alloy bush (4) over the *tool and position the bush so that the leading, tapered edge is against the hole of the bearing plate. Using a soft head (ie. rubber or hide) mallet tap the bush squarely into position taking care not to strike or scratch the mixing assembly.

6.3.5 Refit the drive shaft and rotor (2) into the mixing assembly.



NOTE: Inspect the condition of the drive shaft and rotor assembly (2); a replacement assembly should be fitted if there are signs of wear or damage.

6.3.6 Refit tubular mixing assembly to the mixer body. (Refer to Para 3.3)

6.3.7 Fit a head / screen as required. (Refer Para. 5.17)

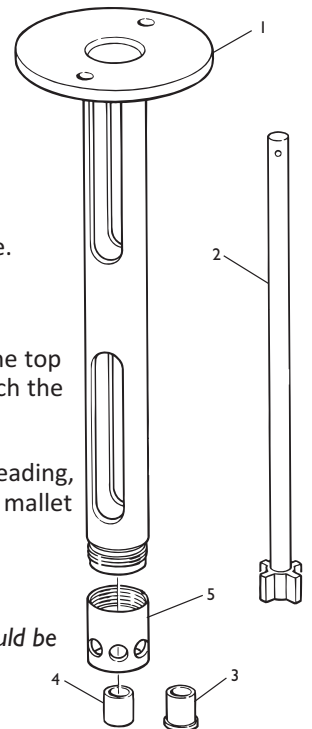

Fig. 17 Replacing the Bush of the 3/4" & 5/8" Mixing Assembly

* Silverson Machines Tool Number SD505.

6.4 REPLACING THE BUSH OF THE 3/8" MINI-MICRO TUBULAR MIXING ASSEMBLY

6.4.1 Remove the tubular mixing assembly from the mixer body. (Refer to Para. 3.3).

6.4.2 With the rotor removal rod** inserted through the hole in the top of the drive shaft (2) locate the rotor removal tool** over the blades of the rotor (5). Using the rod** as a locking bar against the sides of the frame apertures, rotate the tool** to unscrew the rotor from the shaft. Once separated, the rotor (5) can be removed from the bottom of the tubular frame.

The shaft (2) is then withdrawn through the top of the frame.



WARNING: THE ROTOR BLADES MAY BE SHARP.

6.4.3 PTFE BUSH

The PTFE bush (3) is a push-fit and can be easily prized out or pushed into the bearing plate.

6.4.4 Refit the drive shaft and rotor (2) into the mixing assembly.



NOTE: Inspect the condition of the drive shaft and rotor assembly (2) ; a replacement assembly should be fitted if there are signs of wear or damage.

6.4.5 Refit tubular mixing assembly to the mixer body. (Refer to Para. 3.3)

6.4.6 Fit a head / screen as required. (Refer Para. 5.17)

**The rotor removal rod and tool are supplied with the tubular frame.

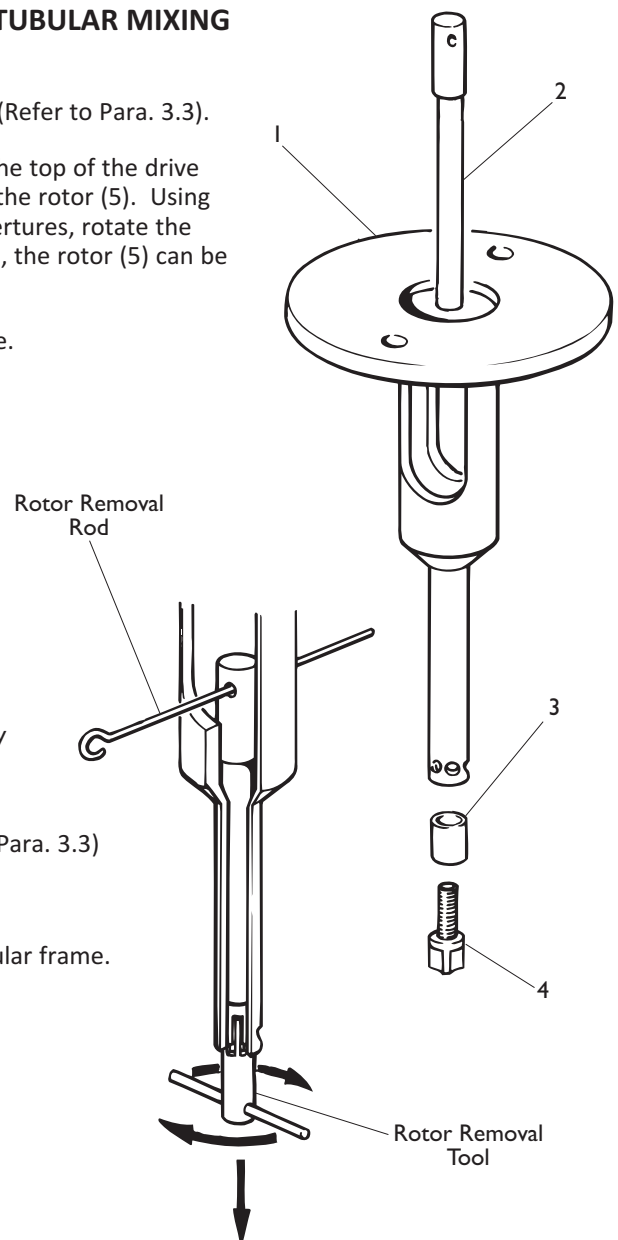

Fig. 18 Replacing the Bush of the 3/8" Mini-Micro Mixing Assembly

6.5 REPLACING THE BUSH - LABORATORY DUPLEX MIXING ASSEMBLY

6.5.1 Remove the duplex mixing assembly from the Mixer body, refer to Para. 3.3, taking care to support the drive shaft and rotors assembly (2) upon removal of the shaft retaining pin until the upper rotor (5) rests on the bearing housing.

6.5.2 The shroud (7) may be removed to increase accessibility:- Detach the two mounting brackets (8) by removing the four retaining screws (9) and slide the shroud (7) down over the bearing housing.



NOTE: Measure and record the position of the shroud (9) prior to displacement.

6.5.3 Slacken the two grub screws (6) securing the upper rotor (5) until the rotor slides freely upon the drive shaft (2) and withdraw the drive shaft and lower rotor through the bearing plate. Take care to retain the upper rotor (5) once disengaged from the shaft.



WARNING: THE ROTOR BLADES ARE SHARP.

6.5.4 Remove the upper and lower heads/ screens - Refer to Para. 5.18

6.5.5 Remove and fit replacement bushes (3 or 4) with reference to Paragraph 6.1.

6.5.6 Refit the upper and lower heads/ screens - Refer to Para. 5.18

6.5.7 Refit the drive shaft and lower rotor (2) into the mixing assembly (1) and refit the upper rotor (5) by applying the removal procedure described in Para. 6.5.3 above, in reverse. Ensure that the screws are tight.



NOTE: Inspect the condition of the drive shaft and rotors (2 and 5); replacement parts should be fitted if there are signs of wear or damage.

6.5.8 Refit the shroud (7).

6.5.9 Refit the duplex mixing assembly to the mixer body. (Refer to Para. 3.3).

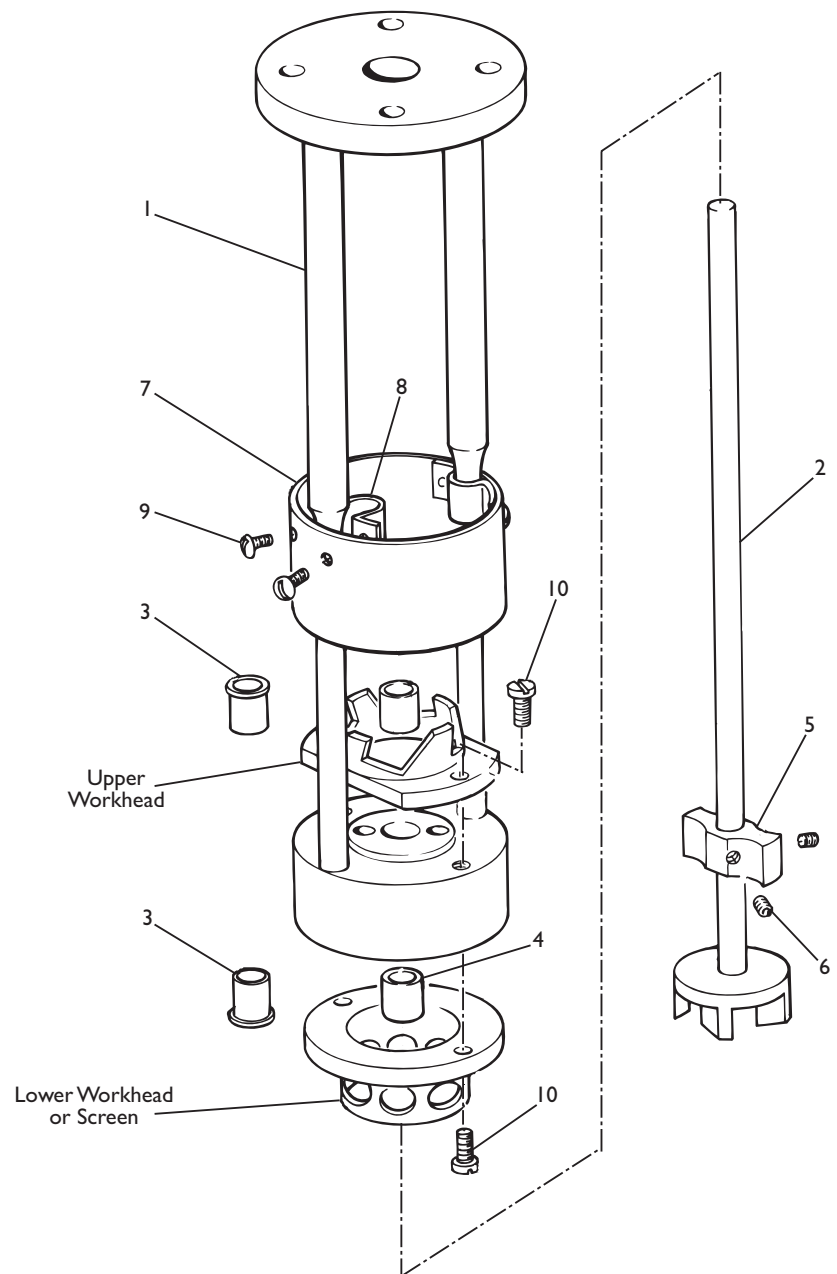

Fig. 19 Replacing the Bush of the Laboratory Duplex Mixing Assembly

6.0 Maintenance



6.6 REPLACING THE BUSH - LABORATORY IN-LINE MIXING ASSEMBLY. (SEE FIG. 20).

- 6.6.1 Remove the In-Line mixing assembly from the Mixer body, refer to Para. 3.3
- 6.6.2 Turn the In-Line mixing assembly thro' 180° and stand on its mounting flange. Remove the four knurled nuts (8).
- 6.6.3 Carefully raise the mounting plate (6) vertically to avoid the head/ screen (14) striking the rotor blades. Retrieve the 'O' ring (7).
- 6.6.4 Insert the rotor removal rod* through the hole in the top of the drive shaft (2) and locate the rotor removal tool* over the blades of the rotor (5). Using the rod* as a locking bar against the sides of the In-Line body apertures, rotate the tool* to unscrew the rotor from the shaft; this is a standard right hand thread. Once separated, the rotor (5) is withdrawn out of the bottom of the In-Line body (1), the shaft (2) can be withdrawn through the top of the In-Line body complete with the rotating section of the mechanical shaft seal (11).



WARNING: THE ROTOR BLADES MAY BE SHARP.

- 6.6.5 Detach the bearing housing (9) from the lower body cavity by removing the two cap head screws (24). Remove and fit a replacement bush (3 or 4) with reference to Paragraph 6.1. Refit the bearing housing (9) ensuring that mating surfaces are clean.
- 6.6.6 Inspect the mechanical shaft seal (11) for signs of physical damage or uneven wear and replace if necessary - refer to Para. 5.26
- 6.6.7 Refit the drive shaft (2) and rotor (5) into the mixing assembly by applying the removal procedure described in Para. 6.6.4 above, in reverse.



NOTE: Inspect the condition of the drive shaft and rotor assembly (2 and 5) ; a replacement assembly should be fitted if there are signs of wear or damage.

- 6.6.8 Locate the 'O' ring (7) into the mounting plate recess (6) and ensure that it is seated correctly, refit the mounting plate to the in-line body (1) and secure using the four knurled nuts (8).
- 6.6.9 Refit the In-Line mixing assembly to the Mixer body. (Refer to Para. 3.3)



* The rotor removal rod and tool are supplied with the laboratory In-Line Mixer / Homogeniser.

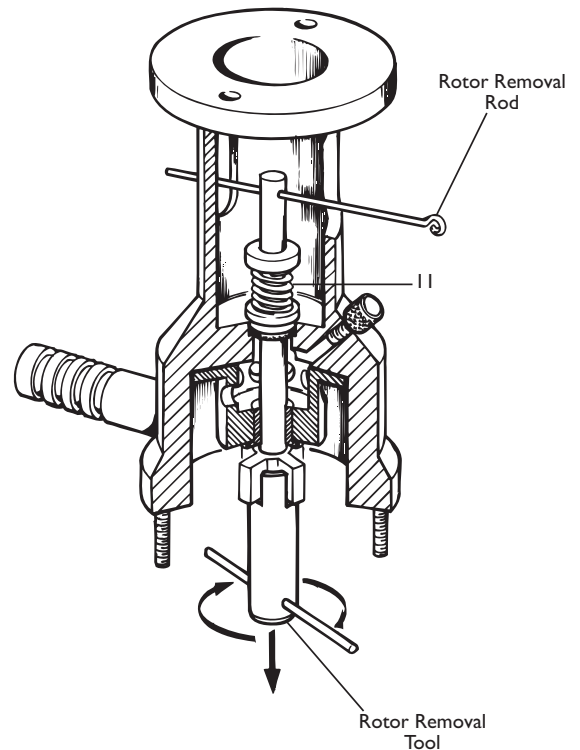
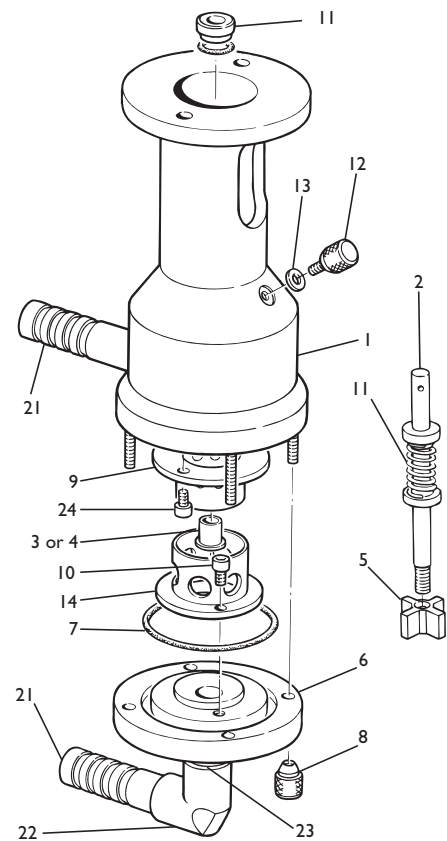

Fig. 20 Replacing the Bush - Laboratory In-Line Mixing Assembly

6.7 REPLACING THE MECHANICAL SHAFT SEAL - IN-LINE MIXING ASSEMBLY (SEE FIG. 21).

- 6.7.1 Remove the drive shaft (2) and rotor assembly (5) from the In-Line body as described in Paragraphs 6.6; the upper rotating section of the mechanical shaft seal will remain on the drive shaft when withdrawn from the In-Line body (1).
- 6.7.2 Slide the upper rotating section of the mechanical shaft seal off the drive shaft (2).
- 6.7.3 Push the stationary seal seat section of the mechanical shaft seal and the seal seat 'O' ring out of the recess within the In-Line body using a bar of suitable diameter placed against the seal face. Take care not to strike or scratch the In-Line mixer body.
- 6.7.4 Fit the replacement seal seat 'O' ring into the recess within the In-Line body. Ensure the 'O' ring is seated against the lower face of the recess.
- 6.7.5 Locate the replacement stationary seal seat so that the smaller diameter of the seat locates into the 'O' ring.
- 6.7.6 Push the stationary seal seat squarely into the recess using finger pressure only until fully home.
- 6.7.7 Slide the replacement rotating section of the mechanical shaft seal onto the drive shaft so that the spring sits against the shaft shoulder. The spring seat should move freely upon the shaft (2) .
- 6.7.8 Refit the drive shaft (2) and reassemble the in-line unit with reference to Paragraphs 6.6.

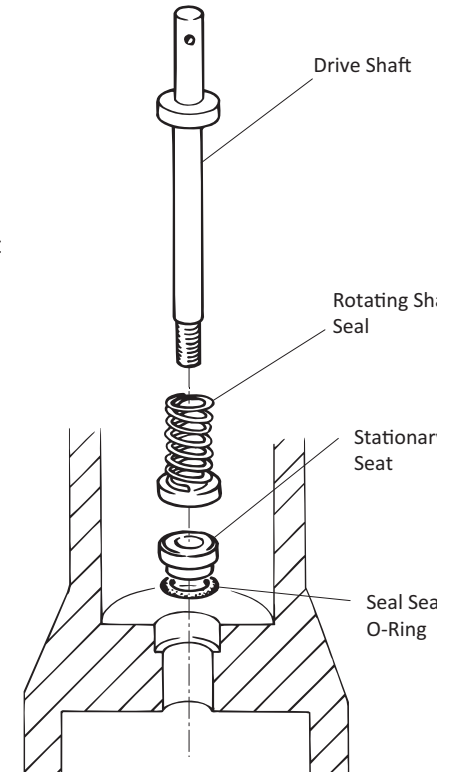

Fig. 21 Replacing the Mechanical Shaft Seal - Laboratory In-Line Mixing Assembly

6.8 GAINING ACCESS TO THE MIXER BODY INTERIOR

(IN ORDER TO CARRY OUT INSTRUCTION 6.9)

- 6.8.1 Remove the four cap head screws (1) from the top of the column unit (2) and remove the two screws (3) and the securing strip (4) from the rear of the plastic cap (5) on the top of the column.
- 6.8.2 Remove the cap (5) from the top of the column. The cap is a tight fit but can be removed by the application of hand pressure. Do not use tools which may scratch the column.
- 6.8.3 Remove the four screws (6) at each corner of the black nylon dust seal (7).
- 6.8.4 Unscrew the four front bezel retaining screws (8) and remove the front bezel (9).
- 6.8.5 Remove the two upper screws (10) retaining the top cover (11) to the rear panel (12).
- 6.8.6 The top cover (11) can now be lifted clear of the column (2) which will provide sufficient access to the motor. Take care not to lose the sealing strips (13).
- 6.8.7 Reassemble the mixer body by applying the above removal procedure in reverse. Ensure that all electrical connections are secure.

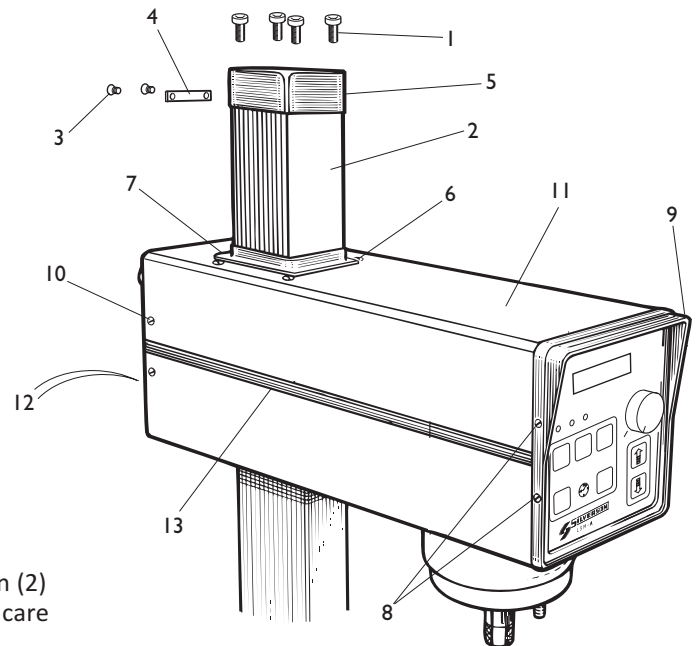

Fig. 22 Gaining Access to the Mixer Body

6.9 REPLACING THE MOTOR BRUSHES AND CLEANING THE MOTOR ARMATURE



WARNING: AVOID INHALATION OF CARBON DUST

- 6.9.1 Gain access to the mixer body - Refer to Section 6.8.
- 6.9.2 Refer to Fig. 23A. Detach the tachometer cable (1) by squeezing the small clamps on each side of the tachometer cable together and pulling out the cable. Detach the earth lead (2) from the motor and detach the power cables (3) from the PCB.
- 6.9.3 Unscrew and remove the two plastic caps (Fig. 23B) from each side of the motor to reveal the motor brushes. Care must be taken as the brushes are sprung loaded and the caps may pop out once released.
- 6.9.4 Withdraw the brushes (Fig. 23C) and inspect them for wear or damage. If less than 6mm (1/4") of carbon remains, the brushes must be replaced.
- 6.9.5 Remove the two motor body screws and washers (Fig. 23D) and lift the motor body away from the motor base and armature (Fig. 23E & 23F). Take care not to lose the shim washers (4) on the top of the motor shaft.
- 6.9.6 Clean the armature and commutator area of the motor using a clean, dry air supply.
- 6.9.7 Make sure that the shim washers (4) are in position on the top of the motor shaft and refit the motor body to the motor base (Fig. 23G).
- 6.9.8 Refit the existing or replacement brushes (Fig. 23H) and caps (Fig. 23B) and reassemble the motor unit by applying the above removal procedure in reverse.

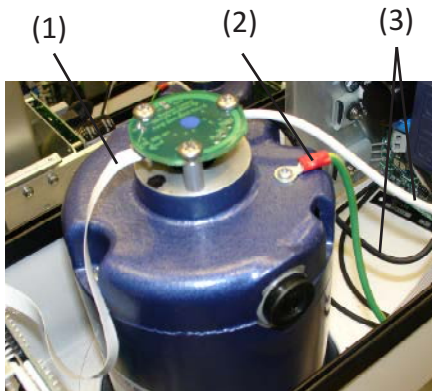

Fig. 23A



Fig. 23B



Fig. 23C



Fig. 23D



Fig. 23E



Fig. 23F



Fig. 23G



Fig. 23H

Fig. 23 Replacing the Motor Brushes and cleaning the Motor Armature

6.10 TROUBLE SHOOTING

The chart below is provided as an aid to tracing and correcting simple faults which may occur from time to time. Your L5M-A mixer was designed for a hard working life and Silverson Machines Limited make every effort to ensure that your mixer is in perfect working order when it leaves the factory. The faults listed below are those which can occur as a result of normal wear and tear.

If you have any difficulty in solving a maintenance or servicing problem or prefer to have your mixer professionally maintained, please do not hesitate to consult Silverson Machines Limited or their accredited representatives.



















WARNING: ALL ELECTRICAL MAINTENANCE SHOULD BE CARRIED OUT BY A QUALIFIED ELECTRICIAN.

The remedy can be carried out by consulting the relevant section of this manual.

The remedy should not be carried out prior to consulting the Maintenance Manual for the mixer. Specific Maintenance Manuals are available from Silverson Machines Limited.

The Mixer must be returned to Silverson Machines Inc. or their accredited agents for repair.

| FAULT | PROBABLE CAUSE | | REMEDY |
|---|---|--|--|
| The digital display unit remains unlit | (i) The rear on/off switch is switched off |  | (i) Switch the rear on/off switch to the 'on' position |
| | (ii) The Mini Circuit Breaker has tripped and automatically switched the rear on/off switch off |  | (ii) Turn power back on by switching the rear on/off switch back to the on position and restart mixer. |
| | (iii) The digital display unit is faulty |  | (iii) Replace the control panel |
| | (iv) The electrical supply is faulty |  | (iv) Check the electrical supply |
| The digital display unit is lit but the rise/fall function is inoperative when the push buttons are pressed | (i) The rise/fall mechanism within the column unit is faulty |  | (i) Return to Silverson Machines for repair. |
| | (ii) Failure of the starter capacitor (s) |  | (ii) Replace the starter capacitor |
| | (iii) Control panel is faulty |  | (iii) Replace the control panel |
| | (iv) The raise and lower motor is faulty |  | (iv) Replace the motor |
| The digital display unit is lit but the mixer drive is inoperative when the speed control is operated | (i) The motor brushes are worn |  | (i) Inspect and replace the motor brushes |
| | (ii) The coupling pin has not been fitted |  | (ii) Fit the coupling pin |
| | (iii) The rotor is obstructed |  | (iii) Inspect the rotor area and clear obstruction |
| | (iv) Failure of the combined on/off and speed control unit |  | (iv) Replace the control panel |
| | (v) Failure of the motor |  | (v) Replace the motor |
| The operating speed of the mixer drive motor is uncontrollable | (i) The motor brushes are worn |  | (i) Inspect and replace the motor brushes |
| | (ii) Failure of the combined on/off and speed control unit |  | (ii) Replace the control panel |
| The mini circuit breaker trips repeatedly | (i) Short circuit in electrical system |  | (i) Check circuit and repair |
| | (ii) Operating in overload condition |  | (ii) Check that the rotor is not obstructed. Check that the viscosity of products is not too high. Check amps during operation. Refer to the technical specification for maximum running load. |

7.0 Technical Specification



7.0 TECHNICAL SPECIFICATION



WARNING: THIS MACHINE IS NOT SUITABLE FOR USE IN A FLAMMABLE / EXPLOSIVE ATMOSPHERE. DO NOT USE THE MACHINE IN A HAZARDOUS AREA WHERE A FLAMMABLE OR EXPLOSIVE ATMOSPHERE MAY BE PRESENT.

Power Supply: 110V

Construction: Wetted parts are manufactured in 316L stainless steel.
Bronze alloy or PTFE bushes are fitted as standard.
All sheet metal components are nylon-coated.

| | Model L5M-A |
|--|--|
| Main Drive Motor Power | 746 W (1 hp) |
| Maximum Speed | 10,000 rpm |
| Maximum full load | 12 amps (60 cycle, 110V motor) |
| Amp Draw | CAUTION: Continuous running above 12 amps will result in the motor stopping and an overload fault will be displayed. |
| Raise and lower starter capacitor | 1 x 30.0µF@250V |
| Nett Weight (including standard mixing assembly) | 25.5 kg (56 lbs) |

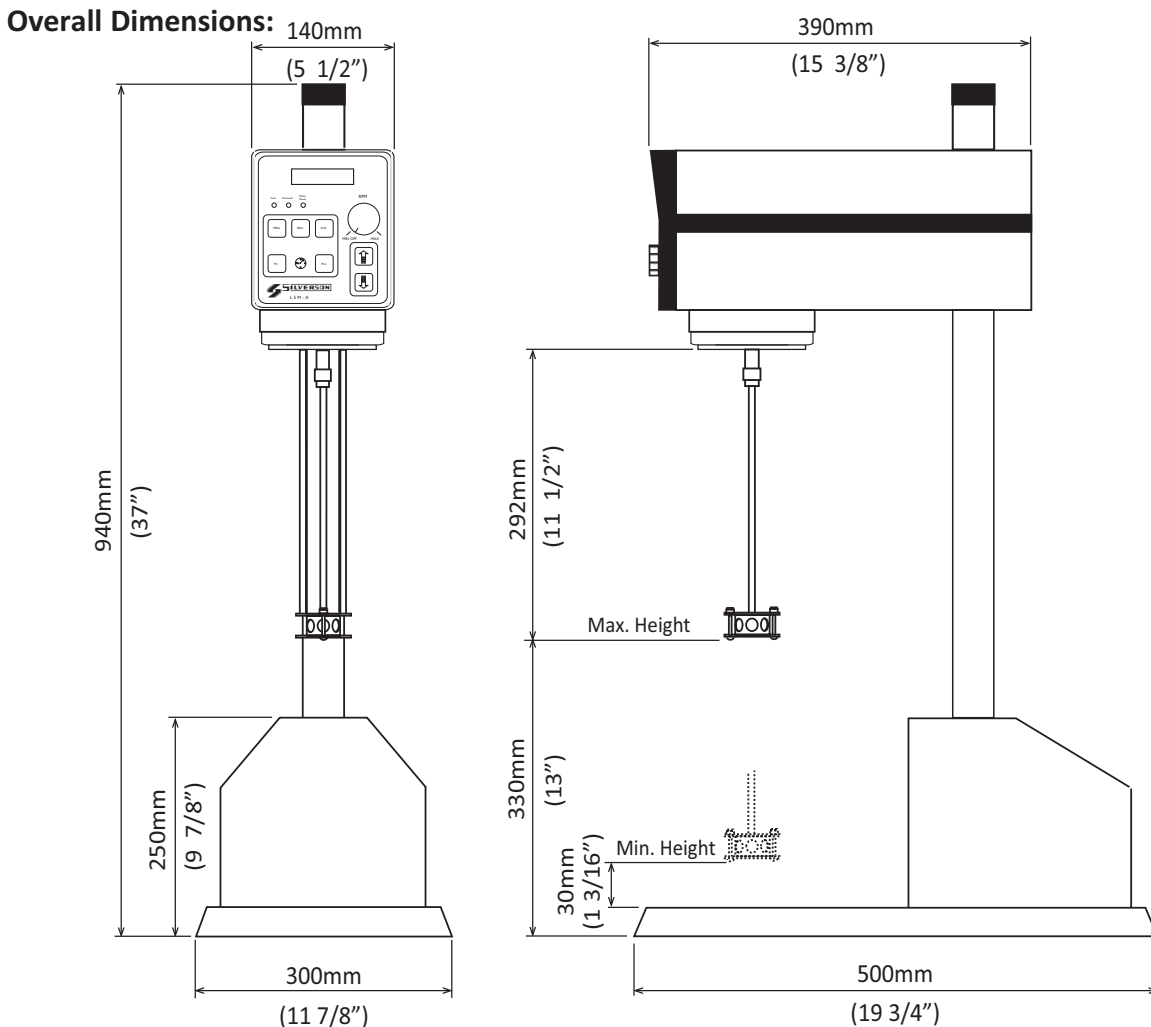

8.0 ILLUSTRATED PARTS LIST

General Laboratory Mixer Assembly

| Item | Part Number | Description | Qty |
|------|-------------|----------------------------------|-----|
| 1 | 7250-CL0001 | Coupling | 1 |
| 2 | 7250-CP0001 | Coupling Pin | 1 |
| 3 | 7250-CS0001 | Coupling Sleeve | 1 |
| 4 | 7250-HN0001 | Knurled Nuts | 2 |
| 5 | 7D00-DE0004 | Electric Motor 110 V 50/60Hz | 1 |
| 6 | 7D00-DB0001 | Brush Set - 110 V Electric Motor | 1 |
| 7 | 7250-WM0001 | Rubber Mat | 1 |
| 8 | 7250-WB0001 | Plastic Bezel | 1 |

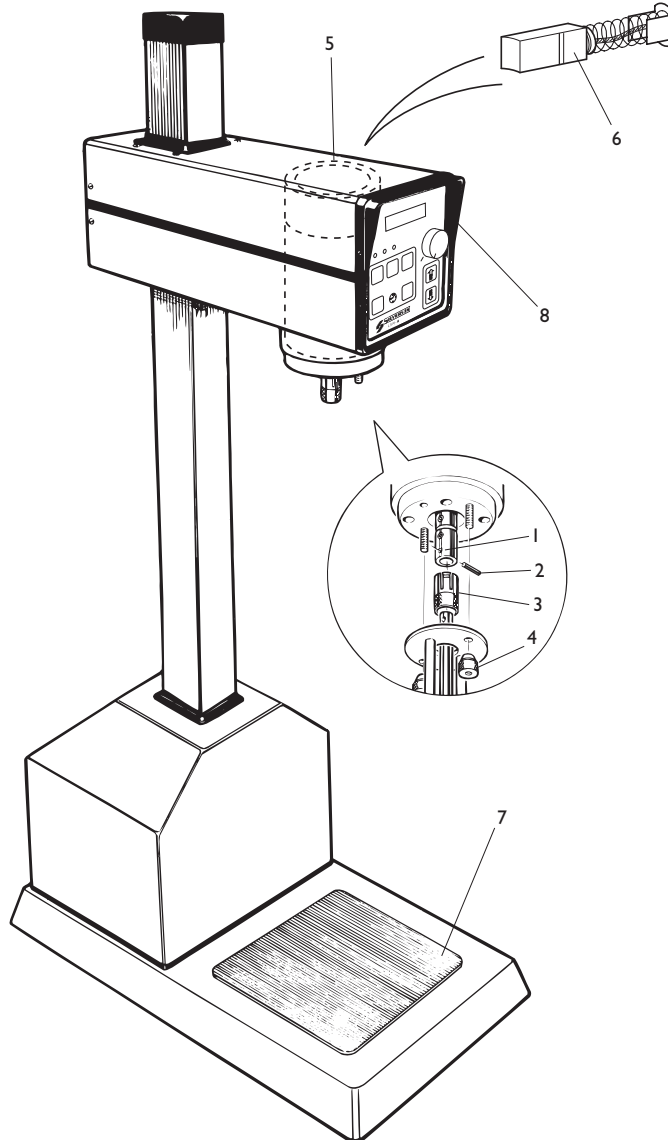

8.0 Illustrated Parts List



Standard Mixing Assembly

| Item | Part No. | Description | Qty |
|----------|-------------|---|-----|
| 1 | 7250-FF0001 | Frame | 1 |
| 2 | 7250-SR0001 | Drive Shaft and Rotor - Standard | 1 |
| Optional | 7250-SR0002 | Drive Shaft and Rotor - With shaft hardened in the journal area | 1 |
| Optional | 7250-SR0017 | Drive Shaft and Rotor - With shaft hardened in the journal area and Hard Tipped Rotor. | 1 |
| 3 | 7250-BP0001 | PTFE Bush (Alternative to item 4) | 1 |
| 4 | 7250-BA0001 | Bronze Alloy Bush (Standard) | 1 |
| 5 | 7250-HR0001 | Base plate | 1 |
| 6 | 7250-HN0001 | Knurled Thumb Nut | 2 |
| 7 | 7250-HG0001 | General Purpose Disintegrating Head | 1 |
| optional | 7250-HG0007 | General Purpose Disintegrating Head - Hard Chromed | 1 |
| 8 | 7250-HQ0001 | Square Hole High Shear Screen | 1 |
| optional | 7250-HQ0010 | Square Hole High Shear Screen - Hard Chromed | 1 |
| 9a | 7250-HE0001 | Standard Emulsor Screen | 1 |
| optional | 7250-HE0006 | Standard Emulsor Screen - Hard Chromed | 1 |
| 9b | 7250-HF0001 | Fine Emulsor Screen | 1 |
| 10 | 7250-HA0001 | Axial Flow Head | 1 |
| *11 | 7250-HS0001 | Vertical Slotted Disintegrating Head | A/R |
| *12 | 7250-HS0007 | Diagonal Slotted Disintegrating Head | A/R |
| *13 | 7250-HP0001 | Pump Head | A/R |

* Optional Accessory

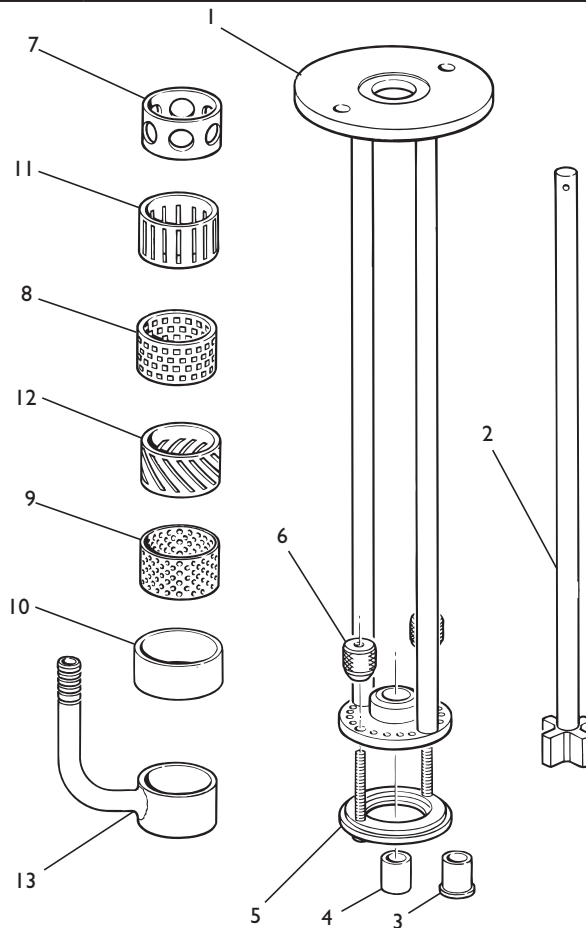

1" and 3/4" Tubular Mixing Assembly

1" Tubular Mixing Assembly

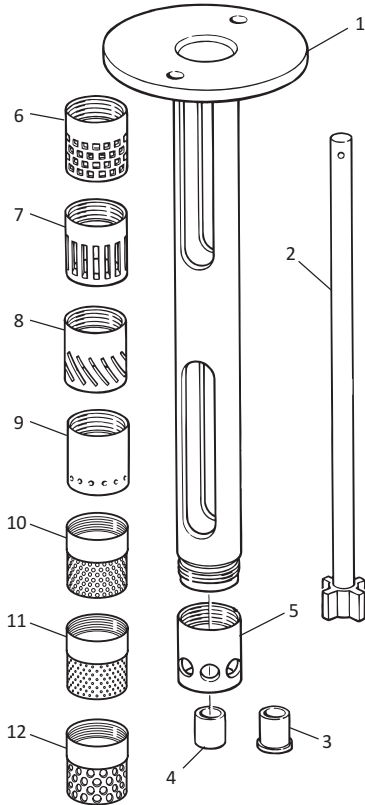

| Item | Part No. | Description | Qty |
|----------|-------------|---|-----|
| 1a | 7250-FF0008 | Frame For Detachable Heads | 1 |
| 1b | 7250-FF0013 | Frame With Integral Open Slotted | 1 |
| | | Disintegrating Head - (Alternative to item 1a) | |
| 1c | 7250-FF0014 | Frame With Integral Diagonal Slotted | 1 |
| | | Disintegrating Head - (Alternative to item 1a) | |
| 2 | 7250-SR0006 | Drive Shaft and Rotor | 1 |
| optional | 7250-SR0010 | Drive Shaft and Rotor - With shaft hardened in the journal area | |
| 3 | 7250-BP0001 | PTFE Bush (Alternative to item 4) | 1 |
| 4 | 7250-BA0001 | Bronze Alloy Bush (Standard) | 1 |
| 5 | 7250-HG0003 | General Purpose Disintegrating Head | 1 |
| 6 | 7250-HQ0005 | Square Hole High Shear Screen | 1 |
| *7 | 7250-HS0003 | Vertical Slotted Disintegrating Head | A/R |
| *8 | 7250-HS0006 | Diagonal Slotted Disintegrating Head | A/R |
| *9 | 7250-HH0002 | Standard Emulsor Head | A/R |

* Optional Accessory

3/4" Tubular Mixing Assembly

| Item | Part No. | Description | Qty |
|----------|-------------|---|-----|
| 1a | 7250-FF0007 | Frame For Detachable Heads | 1 |
| 1b | 7250-FF0011 | Frame With Integral Open Slotted Dis. | |
| | | Head - (Alternative to item 1a) | 1 |
| 1c | 7250-FF0016 | Frame With Integral Diagonal Slotted Dis. | |
| | | Head - (Alternative to item 1a) | 1 |
| 2 | 7250-SR0005 | Drive Shaft and Rotor | 1 |
| optional | 7250-SR0009 | Drive Shaft and Rotor - With shaft hardened in the journal area | |
| 3 | 7250-BP0001 | PTFE Bush (Alternative to item 4) | 1 |
| 4 | 7250-BA0001 | Bronze Alloy Bush (Standard) | 1 |
| 5 | 7250-HG0002 | General Purpose Disintegrating Head | 1 |
| 6 | 7250-HQ0003 | Square Hole High Shear Screen | 1 |
| *7 | 7250-HS0002 | Vertical Slotted Disintegrating Head | A/R |
| *8 | 7250-HS0011 | Diagonal Slotted Disintegrating Head | A/R |
| *9 | 7250-HH0001 | Standard Emulsor Head | A/R |
| *10a | 7250-HE0002 | Standard Emulsor Screen | A/R |
| *10b | 7250-HF0002 | Fine Emulsor Screen | A/R |
| *10c | 7250-HC0002 | Coarse Emulsor Screen | A/R |

* Optional Accessory

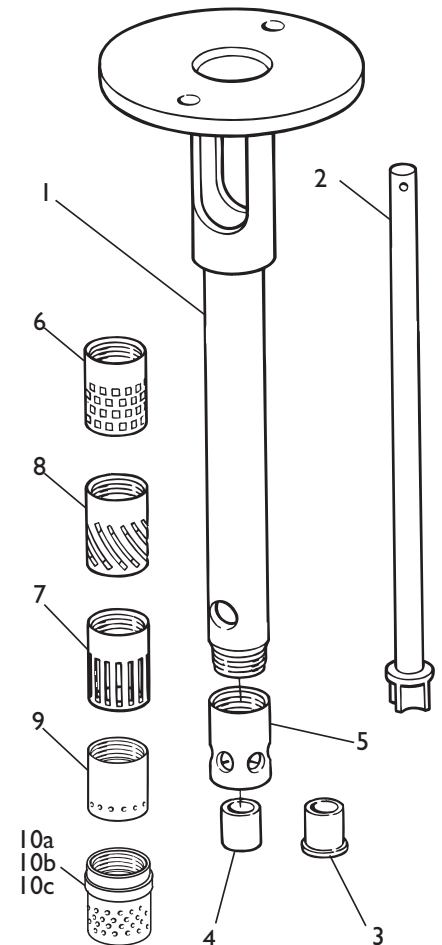

8.0 Illustrated Parts List



5/8" and 3/8" Micro Tubular Mixing Assembly

5/8" Micro Tubular Mixing Assembly

| Item | Part No. | Description | Qty |
|----------|-------------|--|-----|
| 1A | 7250-FF0004 | Frame Assembly - General Purpose Disintegrating Head | 1 |
| 1B | 7250-FF0006 | Frame Assembly - Open Ended Vertical Slotted Disintegrating Head | 1 |
| 2 | 7250-SR0004 | Drive Shaft and Rotor | 1 |
| optional | 7250-SR0008 | Drive Shaft and Rotor - With shaft hardened in the journal area | 1 |
| 3 | 7250-BP0001 | PTFE Bush (Alternative to item 4) | 1 |
| 4 | 7250-BA0001 | Bronze Alloy Bush (Standard) | 1 |

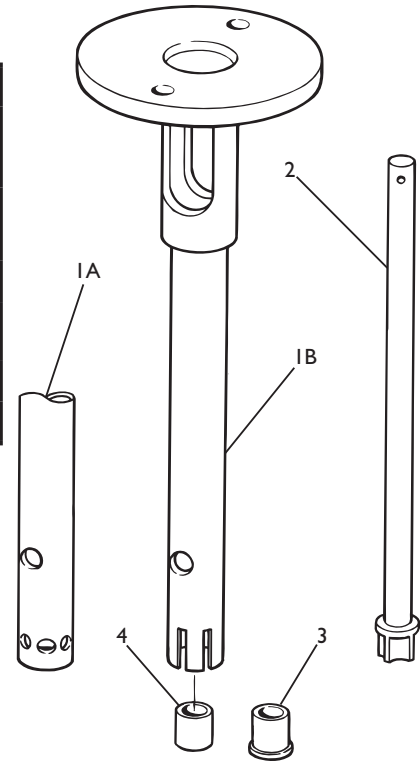

3/8" Mini Micro Tubular Mixing Assembly

| Item | Part No. | Description | Qty |
|------|-------------|--|-----|
| 1A | 7250-FF0002 | Frame Assembly - General Purpose Disintegrating Head | 1 |
| 1B | 7250-FF0003 | Frame Assembly - Open Ended Vertical Slotted Disintegrating Head | 1 |
| 2 | 7250-SS0002 | Shaft | 1 |
| 3 | 7300-BP0001 | PTFE Bush | 1 |
| 4 | 7300-RR0001 | Rotor | 1 |

Rotor Locking Tool - 7250-TR0005

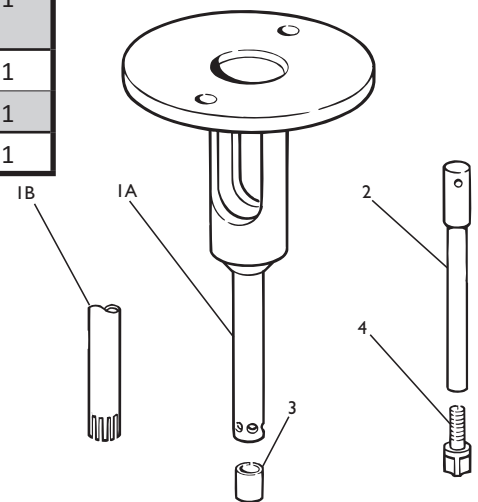

Laboratory Duplex Mixing Assembly

| Item | Part No. | Description | Qty |
|----------|-------------|---|-----|
| 1 | 7250-FF0005 | Frame | 1 |
| 2 | 7250-SR0011 | Drive Shaft and Lower Rotor | 1 |
| optional | 7250-SR0012 | Drive Shaft and Rotor - With shaft hardened in the journal area | 1 |
| 3 | 7250-BP0001 | PTFE Bush (Alternative to item 4) | 2 |
| 4 | 7250-BA0001 | Bronze Alloy Bush (Standard) | 2 |
| 5 | 7250-RR0001 | Upper Rotor | 1 |
| 6 | Q/AGS05/006 | Grub Screw - Upper Rotor | 2 |
| 7 | 7250-GP0001 | Shroud | 1 |
| 8 | 7250-GC0001 | Shroud Clamp | 2 |
| 9 | Q/ARHA004 | Screw - Shroud Clamp | 4 |
| 10 | Q/ACH05/012 | Head/Screen Retaining Screw | 4 |
| 11 | 7250-HT0001 | Coarse Tooth Disintegrating Head (U) | 1 |
| *12 | 7250-HG0005 | General Purpose Disintegrating Head (U) | A/R |
| 13 | 7250-HG0004 | General Purpose Disintegrating Head (L) | 1 |
| *14 | 7250-HQ0007 | Square Hole High Shear Screen (L) | A/R |
| *15 | 7250-HE0004 | Standard Emulsor Screen (L) | A/R |
| *16 | 7250-HS0004 | Vertical Slotted Disintegrating Head (L) | A/R |
| *17 | 7250-HS0012 | Diagonal Slotted Disintegrating Head (L) | A/R |

* Optional Accessory



NOTE:

(U) = For location in the upper position

(L) = For location in the Lower position

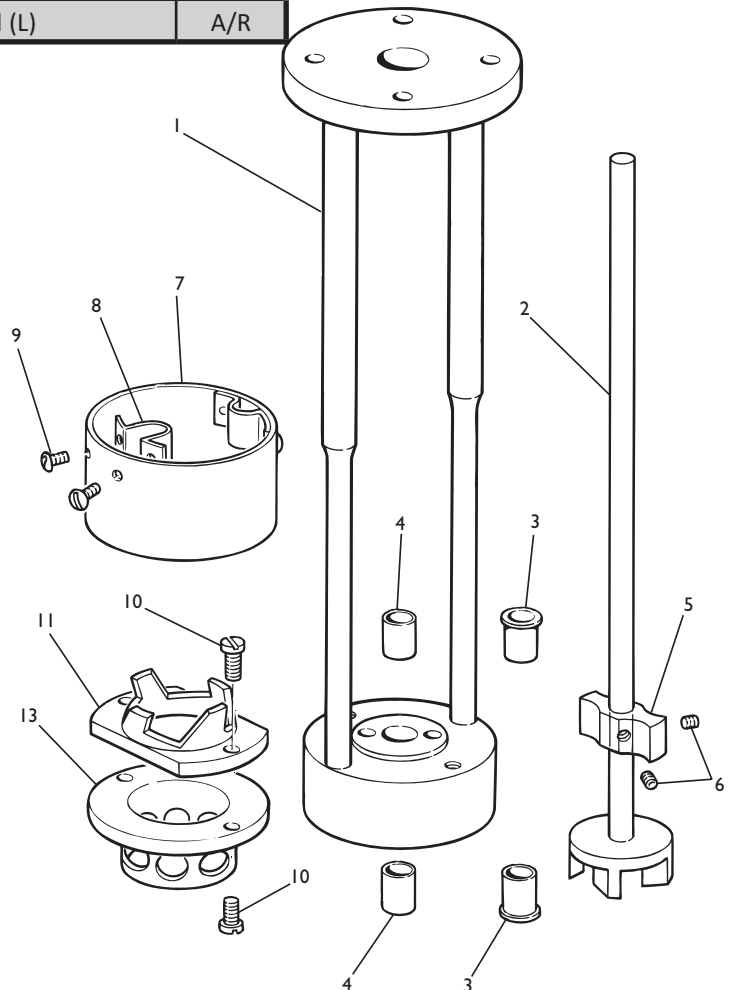
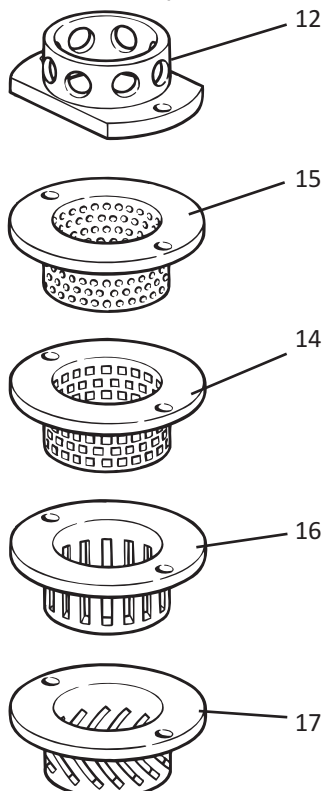

8.0 Illustrated Parts List



| Item | Part No. | Description | Qty |
|----------|---------------------|--|-----|
| 1 | 7250-IS0001 | In-Line Body | 1 |
| 2 | 7250-SR0013 | Drive Shaft and Rotor | 1 |
| optional | 7250-SR0012 | Drive Shaft and Rotor - With shaft hardened in the journal area | |
| 3 | 7250-BP0001 | PTFE Bush (Standard) | 1 |
| 4 | 7250-BA0001 | Bronze Alloy Bush (Alternative to item 3) | 1 |
| 5 | Supplied with shaft | Rotor | 1 |
| 6 | 7250-PI0001 | Stator Mounting Plate | 1 |
| 7 | O/V228 | 'O' Ring - Standard Material = Viton | 1 |
| optional | O/VC228 | 'O' Ring - Optional Material = PTFE | |
| 8 | 7250-HN0001 | Knurled Thumb Nut | 4 |
| 9 | 7250-BH0001 | Bearing Housing | 1 |
| 10 | Q/ACS04/008 | Cap Head Screw | 2 |
| 11 | S/00SU/008C/A01 | Mechanical Shaft Seal - Standard Material: Carbon/Stainless Steel/Viton | 1 |
| optional | S/00SU/008C/A02 | Optional Material: Carbon/Stainless Steel/PTFE/ Kalrez | |
| 12 | 7250-IR0001 | Bleed Screw | 1 |
| 13 | Q/FW05 | Fibre Washer | 1 |
| 14 | 7250-HG0006 | General Purpose Disintegrating Head | 1 |
| 15 | 7250-HQ0002 | Square Hole High Shear Screen | 1 |
| *16 | 7250-HE0005 | Standard Emulsor Screen | A/R |
| *17 | 7250-HS0005 | Vertical Slotted Disintegrating Head | A/R |
| *18 | 7250-HS0010 | Diagonal Slotted Disintegrating Head | A/R |
| - | - | - | - |
| *20 | 7250-HF0005 | Fine Emulsor Screen | A/R |
| **21 | 7250-IB0001 | Inlet / Outlet Hose Tail Tube | 2 |
| **22 | Y/ABE006 | Elbow Joint | 1 |
| **23 | Y/ABN006 | Barrel Nipple | 1 |
| 24 | Q/ACS05/010 | Cap Head Screw | 2 |

Laboratory In-Line Mixer Assembly

Tools:

Rotor Locking Tool: 7250-TR0001

Pin: 7250-TP0001

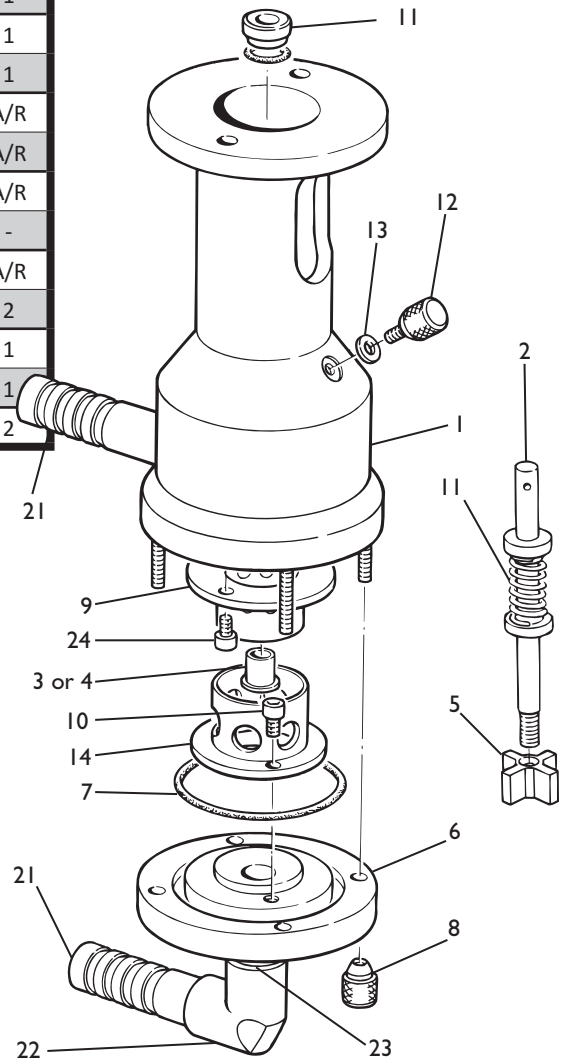

* Optional Accessory

** Fit using Loctite 577 or equivalent

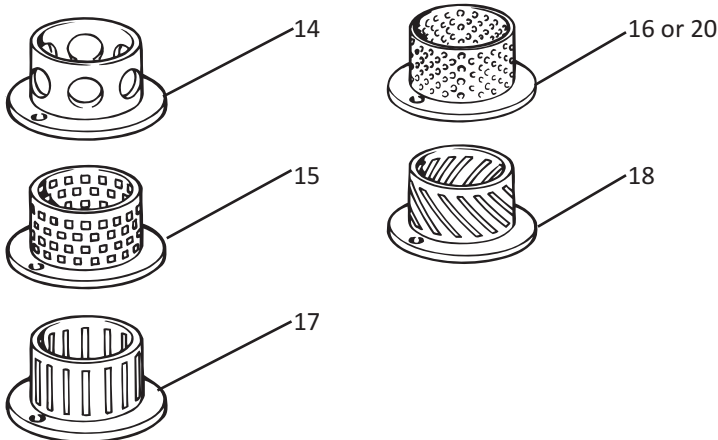

ADDENDUM FOR MANUAL - LAB-072-L5M-A

The purpose of this addendum is to highlight the differences of the Ultramix mixing assembly from the standard L5M-A mixing assemblies (Where Sections are identical to the main manual, it will be stated - Refer to the Main Manual & or Section)

INSTALLATION,
OPERATING & MAINTENANCE
INSTRUCTIONS MANUAL

FOR

HIGH SHEAR
LABORATORY MIXER

MODEL L5M-A

Fitted With Ultramix Mixing Assembly



1A.0 Introduction



1A.0 INTRODUCTION - REFER TO MAIN MANUAL

2A.0 Safety



2A.0 SAFETY



CAUTION: The dynamic mixing head of the Ultramix mixer and at least one third of the drive shaft must be fully immersed in the product BEFORE operating the mixer to provide stability. Failure to observe this precaution may lead to excessive vibration causing serious mechanical damage.



NOTE: Refer to Section 2 of the Main Manual for all Safety precautions.

3A.0 Installation



3A.0 INSTALLATION

3A.1 UNPACKING - REFER TO MAIN MANUAL

3A.2 ELECTRICAL INSTALLATION - REFER TO MAIN MANUAL

3A.3 FITTING THE ULTRAMIX MIXING ASSEMBLY (Refer to FIG. 1A)

3A.3.1 Unscrew and remove the two knurled nuts (4).

3A.3.2 Slide the coupling sleeve (3) up the drive shaft coupling (1) to reveal the coupling pin (2).

3A.3.3 Use a piece of rod of suitable diameter to push out the coupling pin (2). (The tip of a ball point pen will suffice!)

3A.3.4 Locate the mixing assembly (6) onto the two studs ensuring that the mating surfaces are clean.



Note: Where there is insufficient clearance refer to Para. 5.1 and raise the mixer body.

3A.3.5 Refit the knurled nuts (4) with the narrow end positioned against the flange.

3A.3.6 Correctly align the drive shaft coupling (1) and drive shaft (5) and insert the coupling pin (2).

3A.3.7 Slide the coupling sleeve (3) down the coupling until the clip engages into the groove of the coupling thus captivating the coupling pin (2).



NOTE: FOR THE REMOVAL OF THE MIXING FRAME ASSEMBLY APPLY THE ABOVE FITTING PROCEDURE IN REVERSE.



CAUTION: WHEN REMOVING THE MIXING FRAME ASSEMBLY CARE SHOULD BE TAKEN WHEN EXTRACTING THE PIN (2) TO SUPPORT THE DRIVE SHAFT (5).

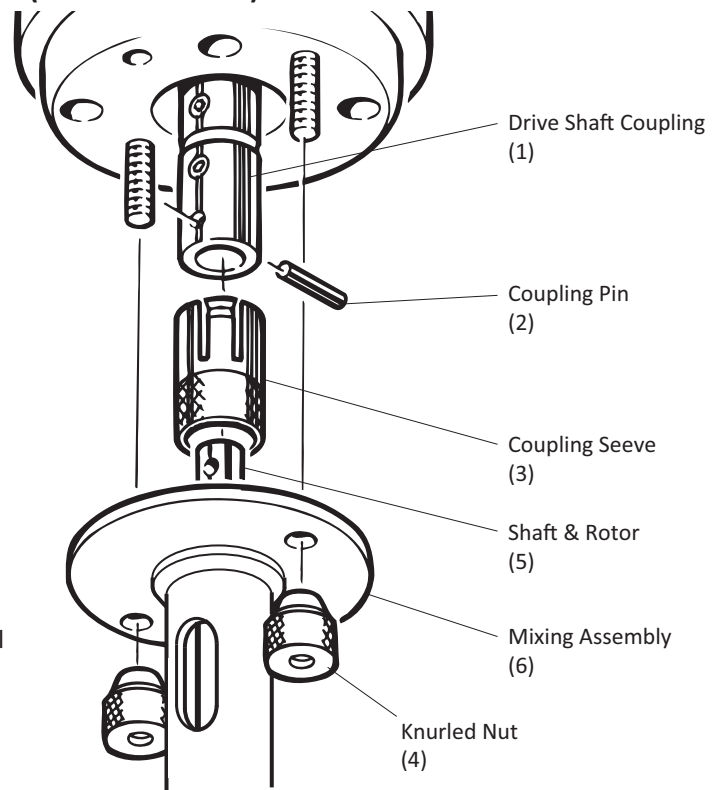

Fig. 1A Fitting The Ultramix Mixing Assembly

4A.0 DESCRIPTION

4.1 GENERAL - REFER TO MAIN MANUAL

4.1.1 - 4.1.3 - REFER TO MAIN MANUAL

4A.3 ULTRAMIX MIXING ASSEMBLY

The Ultramix mixing assembly is a tubular construction with a PTFE or Rulon bush. The drive shaft and mixing head assembly is detachable from the tubular frame.

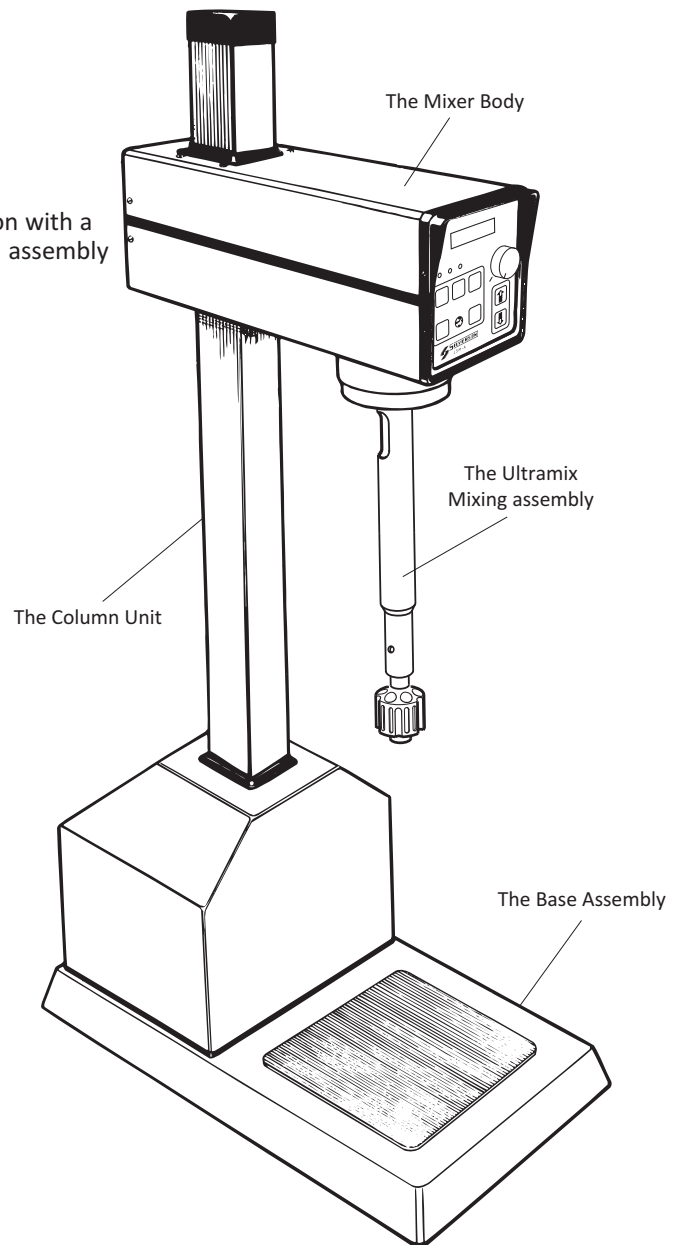

Fig. 2A The L5M-A Laboratory Mixer Fitted with an Ultramix Mixing Assembly

5A.1 OPERATION - REFER TO MAIN MANUAL (except for caution below)



CAUTION: The dynamic mixing head of the Ultramix mixer and at least one third of the drive shaft must be fully immersed in the product BEFORE operating the mixer to provide stability. Failure to observe this precaution may lead to excessive vibration causing serious mechanical damage.

5A.2 GENERAL GUIDELINES FOR MIXING REFER TO MAIN MANUAL (except for caution below)



CAUTION: The dynamic mixing head of the Ultramix mixer and at least one third of the drive shaft must be fully immersed in the product BEFORE operating the mixer to provide stability. Failure to observe this precaution may lead to excessive vibration causing serious mechanical damage.

5.2.1 Positioning The Head/Screen - REFER TO MAIN MANUAL

5.2.2 Setting The Speed - REFER TO MAIN MANUAL

5A.3 PRINCIPLES OF ULTRAMIX OPERATION

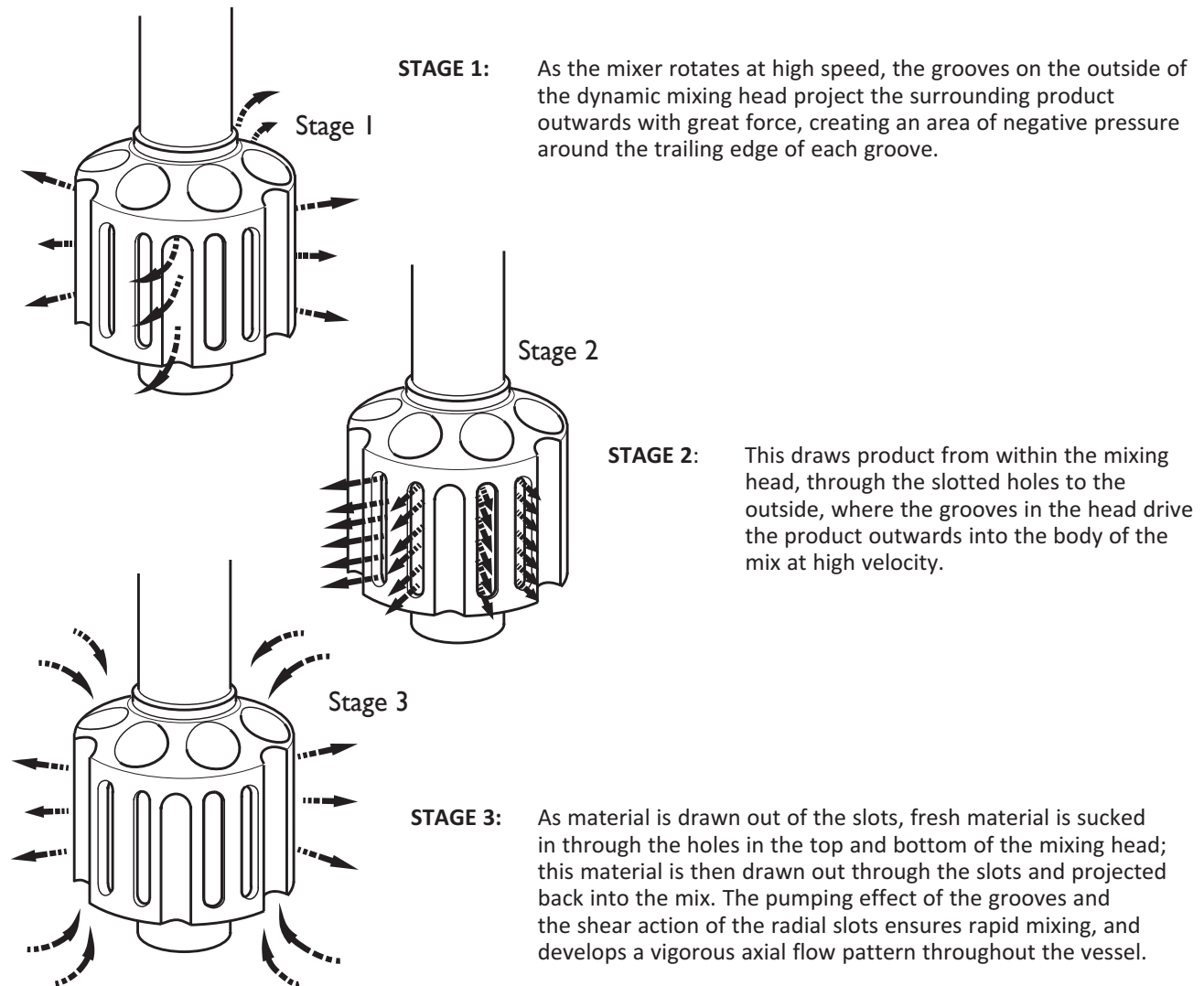

Fig. 3A Principles of Ultramix Operation

5A.4 CLEANING

5A.4.1 The L5M-A mixer is in most cases self cleaning, a short run between successive mixing operations in water, detergent or an appropriate non-flammable solvent should be all that is necessary to clean the wetted parts. For more thorough cleaning, dismantling is easy and downtime minimal.

5A.4.2 The housing and wetted parts can be cleaned with household cleaning agents providing that they do not contain solvents and are non-scratching. Do not scour the parts with sharp objects.



WARNING: IF IT IS NECESSARY TO USE FLAMMABLE SOLVENTS TO CLEAN MIXED PRODUCT OFF THE WETTED PARTS, THEN THE MIXING ASSEMBLY MUST BE REMOVED AND CLEANED IN A SAFE AREA, AWAY FROM THE MACHINE.



WARNING: THE MACHINE SHOULD NEVER BE SPRAYED WITH WATER OR IMMERSSED IN WATER.

5A.4.3 The materials of construction of the wetted parts are compatible with all commonly used cleaning chemicals.

Most sanitising chemicals, such as those that contain active chlorine, iodine etc. are corrosive, to some extent to stainless steel. Where these chemicals are used, 316 Stainless Steel should be specified.



CAUTION: Where Sodium Hypochlorite solutions are used for sterilising the mixer, their maximum concentration should be 150 ppm available Chlorine at a maximum temperature of 40°C, and an absolute maximum time of 20 minutes. Failure to observe this precaution may result in corrosion of even 316 Stainless Steel.



WARNING: SUITABLE PROTECTIVE CLOTHING SHOULD BE WORN WHEN HANDLING AND USING CLEANING CHEMICALS. NATIONAL, LOCAL AND SITE REGULATIONS SHOULD BE OBSERVED.

6A.0 MAINTENANCE PROCEDURES



WARNING: ALWAYS ISOLATE THE MACHINE FROM THE ELECTRICAL SUPPLY BEFORE PERFORMING MAINTENANCE PROCEDURES.

6A.1 REPLACING THE WORKHEAD



WARNING: BEFORE ATTEMPTING TO REPLACE WORKHEAD ENSURE THAT THE MIXER IS ISOLATED FROM THE MAINS SUPPLY.

6A.1.1 Unscrew and remove the two knurled nuts (4).

6A.1.2 Through the upper aperture in the frame (10), slide the coupling sleeve (3) up the coupling (1) until the coupling pin (2) is visible.

6A.1.3 Using a like sized rod or tube, gently push the coupling pin (2) free from the coupling (1) and remove the complete mixing frame assembly.



CAUTION: Before attempting to remove the coupling pin (2), ensure that the frame (10) and driveshaft assembly (11) are adequately supported and prevented from falling.

6A.1.4 Slide the driveshaft (11), complete with workhead (14) out of the frame (10) and remove the spacer (13) which is loose on the shaft.

6A.1.5 While holding the driveshaft (11) unscrew and remove the dome nut (15) then unscrew the workhead (14) from the shaft (11).



NOTE: The workhead has a standard right hand thread.

6A.1.6 Screw a replacement workhead (14) onto the driveshaft (11) ensuring that it fully abuts against the shoulder of the shaft. Refit the dome nut (15) and fully tighten.

6A.1.7 Ensure that the PTFE or Rulon bush (12) is correctly located into the base of the frame (10). Refit the spacer (13) over the driveshaft (11).

6A.1.8 Carefully offer the driveshaft straight and in line with the PTFE or Rulon bush (12) and push the driveshaft and workhead assembly into the frame (10) and relocate the mixing frame assembly onto the mixer.

6A.1.9 Refit the knurled nuts (4) with the narrow end positioned against the flange.

6A.1.10 Rotate the drive shaft (11) until the hole is aligned within the coupling (1) and insert the coupling pin (2).

6A.1.11 Slide the coupling sleeve (3) down the coupling until the clip engages into the groove of the coupling thus captivating the coupling pin (2).

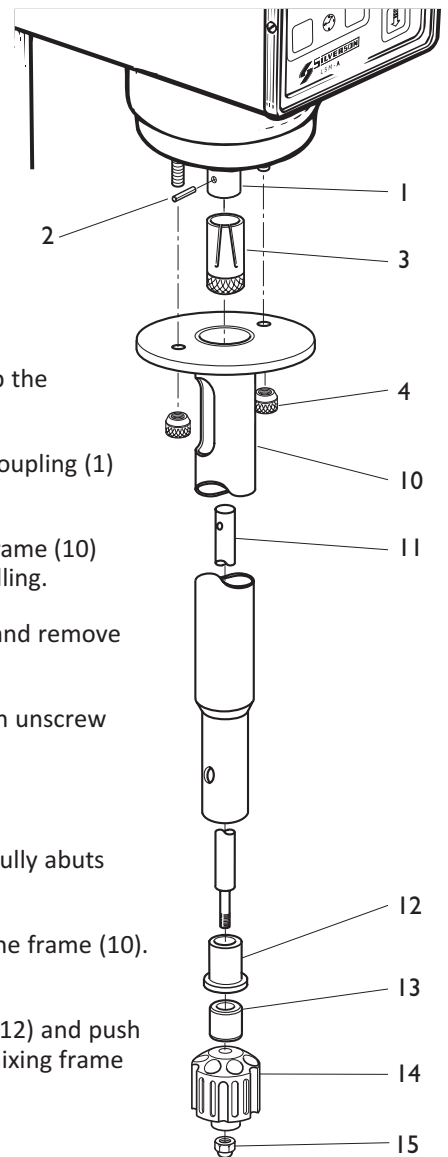



Fig. 24 Replacing the Workhead of the Ultramix Mixing Assembly

6A.2 REPLACING THE PTFE OR RULON BUSH

 **NOTE:** All mixing assemblies have a PTFE or Rulon bush. This bearing bush is lubricated and cooled by the product being mixed during operation. The bush is a wearing part which needs to be replaced at periodic intervals depending on the characteristics of the mix. The bush must be regularly inspected for signs of wear and replaced when necessary. Where there is any perceptible movement of the shaft within the bush, the bush should be replaced.

 **CAUTION:** Failure to replace the bush when required will cause considerable damage to the mixer.

6A.2.1 Remove the mixing frame assembly from the Mixer and slide the drive shaft (11) out of the frame (10) as described in paragraphs 6.1.1 to 6.1.4.

6A.2.2 Using suitable tooling push the PTFE or Rulon Bush (12) out of the bottom of the frame (10).

 **Caution:** Only soft metal or plastic should be used to push out the bush to avoid damaging the mixing frame (10).

6A.2.3 Fit the new PTFE or Rulon bush (12) into the base of the frame (10), ensuring it is aligned square and true and fits flush with the frame.

6A.3 GAINING ACCESS TO THE MIXER BODY INTERIOR - REFER TO MAIN MANUAL (SECTION 6.8) (IN ORDER TO CARRY OUT INSTRUCTION 6A.4.).

6A.4 REPLACING THE MOTOR BRUSHES AND CLEANING THE MOTOR ARMATURE - MODEL L5M-A - REFER TO MAIN MANUAL (SECTION 6.9).

 **WARNING:** AVOID INHALATION OF CARBON DUST

6A.5 TROUBLE SHOOTING - REFER TO MAIN MANUAL (SECTION 6.10)

7A.0 TECHNICAL SPECIFICATION - REFER TO MAIN MANUAL (SECTION 7.0)

8A.0 Illustrated Parts List



8A.0 ILLUSTRATED PARTS LIST

8A.1 General Laboratory Mixer Assembly

| Item | Part Number | Description | Qty |
|------|-------------|----------------------------------|-----|
| | L5M-A | | |
| 1 | 7250-CL0001 | Coupling | 1 |
| 2 | 7250-CP0001 | Coupling Pin | 1 |
| 3 | 7250-CS0001 | Coupling Sleeve | 1 |
| 4 | 7250-HN0001 | Knurled Nuts | 2 |
| 5 | 7D00-DE0004 | Electric Motor 110 V 50/60Hz | 1 |
| 6 | 7D00-DB0001 | Brush Set - 110 V Electric Motor | 1 |
| 7 | 7250-WM0001 | Rubber Mat | 1 |
| 8 | 7250-WB0001 | Plastic Bezel | 1 |

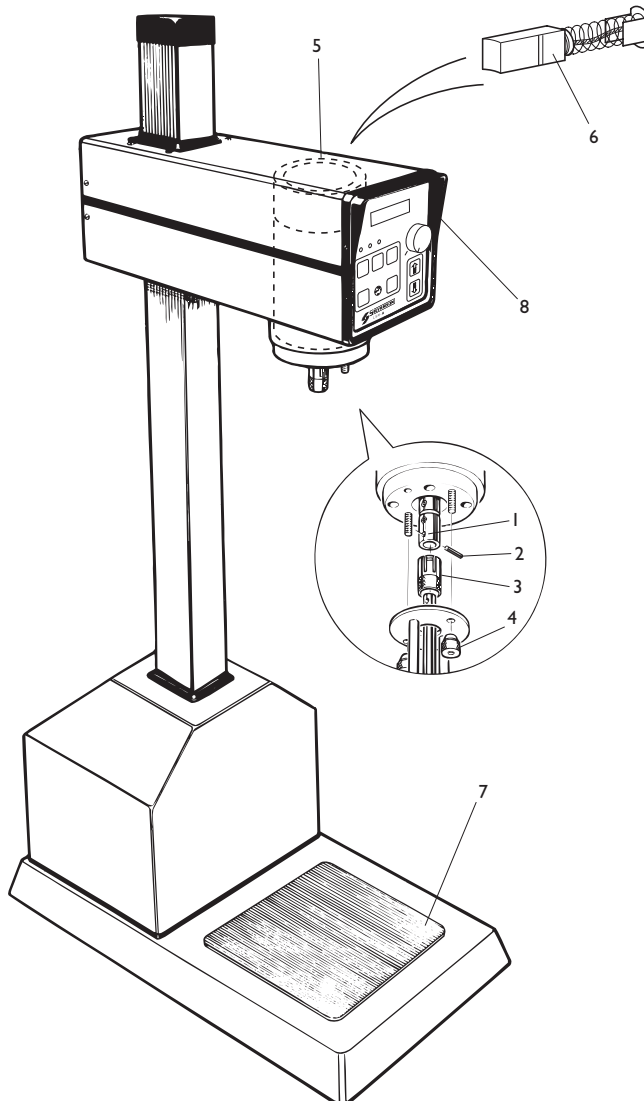

8A.2 Ultramix Mixing Assembly

| Item | Part Number | Description | Qty |
|------|-------------|--------------------------------|-----|
| 10 | AC3904 | Frame | 1 |
| 11 | AC6102 | Drive Shaft | 1 |
| 12 | 7250-BP0001 | PTFE Bush (alternative to 12A) | 1 |
| 12A | 7250-BR0001 | Rulon Bush (alternative to 12) | 1 |
| 13 | AC3968 | Spacer | 1 |
| 14 | AC6280 | Workhead | 1 |
| 15 | Q/ADN05 | Dome Nut | 1 |

